

# South African Pin Shooting Federation (SAPSF)

## Rule Book



Ninth Edition  
Revision 2026-02-28

# Rule Book

The **South African Pin Shooting Federation (SAPSF)** wishes to acknowledge with thanks the efforts of all those involved in compiling this current edition and previous editions of the SAPSF Rule Book.

All rights reserved. No part of this Rule Book may be modified, except by SAPSF.

First Edition:	1996
Second Edition:	
Third Edition:	30/09/2003 (Revision 3)
Fourth Edition:	Rule Book & Activity Register (booklet)
Fifth Edition:	20/11/2012
Sixth Edition:	20/02/2015
Seventh Edition:	31/10/2017
Eighth Edition:	09/02/2020
Ninth Edition	05/09/2024
	Council Approval: 28/02/2026

Contact Information:

SOUTH AFRICAN PIN SHOOTING FEDERATION  
[www.sapinshooting.com](http://www.sapinshooting.com)

*Note: Final version approved and accepted 17February 2026*

# Contents

## Chapters

<b>1. Introduction</b> .....	<b>4</b>
<b>2. Purpose of this Rule Book</b> .....	<b>4</b>
<b>3. General Definitions</b> .....	<b>5</b>
<b>4. Rules &amp; Procedures</b> .....	<b>6</b>
4.1. Basic Firearm Safety Rules .....	6
4.2. Pin Shooting Safety Rules.....	6
4.3. Range Rules .....	9
4.4. Disciplinary Offences.....	10
4.5. Range Commands .....	12
4.6. Scoring of Timed Events .....	15
4.7. Scoring of Elimination Events.....	17
4.8. Team Rules.....	17
4.9. Age Categories.....	18
4.10. Range Set-up .....	19
<b>5. Match Management</b> .....	<b>20</b>
5.1. Match Director ("MD").....	20
5.2. Range Master ("RM") .....	20
5.3. Range Officer ("RO").....	20
5.4. Safety Officer ("SO").....	21
5.5. Timer.....	21
<b>6. Ammunition Classification and Definitions</b> .....	<b>22</b>
6.1. Handgun Calibre Cartridge.....	22
6.2. Rifle Cartridge Calibre Classification Light Rifle:.....	22
6.3. Rifle Cartridge Calibre Classification Rifle: .....	22
6.4. Shotgun Calibre Shell.....	22
6.5. Grandfather Clause .....	22
<b>7. Firearm Classification and Definitions</b> .....	<b>23</b>
7.1. Pistol .....	23
7.2. Revolver.....	23
7.3. Optical Sight.....	23
7.4. Backup Gun .....	23
<b>8. Format for the Pin Shooting Events</b> .....	<b>24</b>
8.1. Handgun and Shotgun Events.....	24
8.2. Rifle and Carbine Events.....	25
8.3. General Table and Pin Setup for Rifle and Carbine Events .....	25

<b>Appendix A. Event Rules and Setup .....</b>	<b>27</b>
<b>Legacy Handgun Events:.....</b>	<b>27</b>
A.1. Pin Gun Event - Five Pins .....	27
A.2. Stock Gun Event - Eight Pins .....	28
A.3. Nine Pin Tip-Over Event – Nine Pins .....	29
A.4. Pin Revolver Event - Five Pin.....	30
A.5. Stock Revolver Event - Eight Pin .....	31
<b>Elective Handgun Events: .....</b>	<b>32</b>
A.6. Pocket Pistol Event - Five Pin .....	32
A.7. Snubby Revolver - Five Pins .....	33
A.8. Rimfire Handgun Event – Five Pins.....	34
A.9. Space Gun Event - Nine Pins.....	35
<b>Elective Rimfire Rifle Events: .....</b>	<b>36</b>
A.10. Rimfire Rifle Manual Event - Five Pins .....	36
A.11. Rimfire Rifle Self-Loading Event - Eight Pin .....	38
<b>Elective Shotgun Events: .....</b>	<b>40</b>
A.12. Shotgun Manual Event - Five Pins .....	40
A.13. Shotgun Self-Loading Event - Five Pin.....	41
A.14. Shotgun Open - Five Pins .....	42
<b>Elective Centre Fire Rifle Events: .....</b>	<b>43</b>
A.15. Light Rifle Manual Event - Five Pins.....	43
A.16. Light Rifle Self-Loading Event - Eight Pins .....	45
A.17. Rifle Manual Event - Five Pins .....	47
A.18. Rifle Self-loading Event - Eight Pins.....	49
A.19. Carbine Manual Event - Five Pins .....	51
A.20. Carbine Self-loading Event - Eight Pins.....	53
<b>Appendix B. Elimination Match.....</b>	<b>55</b>
<b>Appendix C. Quick Reference Summary of Range Commands.....</b>	<b>57</b>
<b>Appendix D. Quick Reference Summary Text of Selected Pin Shooting Events .....</b>	<b>58</b>
<b>Appendix E. SAPSF Member’s Code of Conduct .....</b>	<b>60</b>
<b>Appendix F. Construction Plan for a Double-Tier Table .....</b>	<b>62</b>
<b>Appendix G. General Provisions .....</b>	<b>63</b>
<b>Appendix H. Occupational Health and Safety.....</b>	<b>64</b>
<b>Appendix I. Acknowledgements and Credits.....</b>	<b>68</b>
Special Thanks .....	68
<b>SAPSF Executive Sanction: Rule Book Approval .....</b>	<b>69</b>

# 1. Introduction

Pin Shooting originated in the United States and was developed by Richard Davis, owner Second Chance Body Armor. South African sport shooters adopted the sport in 1996 and established the South African Pin Shooting Federation (SAPSF). SAPSF developed Pin Shooting into a more formal and mature sport, while retaining its exciting format.

The objective in most pin shooting events is to shoot ten-pin bowling pins off a table from a distance of 7.6 m (25 ft). Most handgun events in the sport require the 1.6 kg pins to be driven completely off the back of a 1-meter table, necessitating powerful loads. Some of the events require pins to be shot off a narrow rail and therefore require less powerful firearms and/or loads. There are also events for rifles, shotguns and rimfire firearms. The sport requires competitors to shoot accurately, fast and to be able to manage the recoil of their firearms.

Pin shooting matches are typically timed, with competitors shooting a series of events with different firearms and varying pin configurations. The scores from the five main Legacy (previously Core) events are then aggregated and averaged in order to rank competitors by fastest aggregated time. Matches may be concluded with elimination events, where shooters pit their skills against one another. Elimination events typically do not influence overall match scores.

Pin shooting appeals to all ages of shooters, male and female alike. No strenuous movement is required and the sport is suitable for disabled and aged shooters.

## 2. Purpose of this Rule Book

The Rule Book serves as the definitive manual for all competitive Pin Shooting at club, provincial and national level, as conducted under the auspices of and recognized by SAPSF.

Any item, action, or practice not explicitly covered or permitted in this rule book shall be considered outside the scope of sanctioned provincial and national competitions and may only be allowed at club shoot at the discretion of the Range Officer.

All members, clubs and provincial associations, are required to acquaint themselves with the SAPSF Constitution, the SAPSF Rule Book and the Firearms Control Act (Act 60 of 2000), as well as any other relevant policy documents, and abide thereby.

The Rule Book must be read in conjunction with the SAPSF Constitution.

Pin Shooting is recognized as an official shooting sport by the South African Shooting Sport Confederation (SASSCO) with SAPSF as the sport's sole representative and governing body. SAPSF is accredited with the South African Police Service as a sport shooting organization with accreditation number 1300061. Affiliation with SAPSF is compulsory for any individual or organization who wishes to engage formally in the sport of Pin Shooting in South Africa.

### 3. General Definitions

In this section general terms used in this document are defined.

- a. Pin Shooting is an independent **DISCIPLINE** within the shooting sports.
- b. Pin Shooting competitions are called **MATCHES**, which may be at club, provincial, national or international level.
- c. In each Pin Shooting **MATCH**, competitors participate in a number of **EVENTS**, including the five **LEGACY** events (previously referred to as **CORE** events), namely Pin Gun, Stock Gun, Nine Pin Tip over, Pin Revolver and Stock Revolver.
- d. Each **EVENT** consists of three to four **STRINGS**, referred to as **STRING ONE**, **STRING TWO**, etc. A String is a single round of an **EVENT**. In this, the shooter on the line will engage the pins that have been set up for that **EVENT**, and at the end of the **STRING** the time will be recorded.
- e. Pin shooting targets are always referred to as **PINS**, this may include bowling **PINS**, cardboard **PINS**, metal **PINS**, plastic **PINS**, etc.
- f. The surfaces on which **PINS** are placed can be **PIN TABLES** or **PIN STANDS**.
- g. The surface from which a competitor shoots is to be known as the **RAIL**.
- h. The edge of the **RAIL** closest to the backstop will form the **LINE**. This **LINE** will demarcate the firing line of the range. (see diagram below)
- i. A participant at a pin shooting match will be referred to as a **COMPETITOR**, but addressed as **SHOOTER** when on the firing line.
- j. A **SQUAD** will be made up of **THREE COMPETITORS**, and these three **COMPETITORS** will stay together for an **EVENT**. At club level matches, squads of two competitors are acceptable.
- k. A **DETAIL** will be a group of **SQUADS** assigned to a time slot allocated on the match program when an **EVENT** will take place.
- l. All persons at the match who in some way officiate on the range/ranges are **RANGE OFFICIALS**, including Range Master, Range Officers, Safety Officers, Timers, Tappers, etc.
- m. Other officials shall be known as **MATCH OFFICIALS**, including Match Directors, Scorers, First Aid officials, etc.
- n. Observers at a match shall be referred to as **SPECTATORS**.

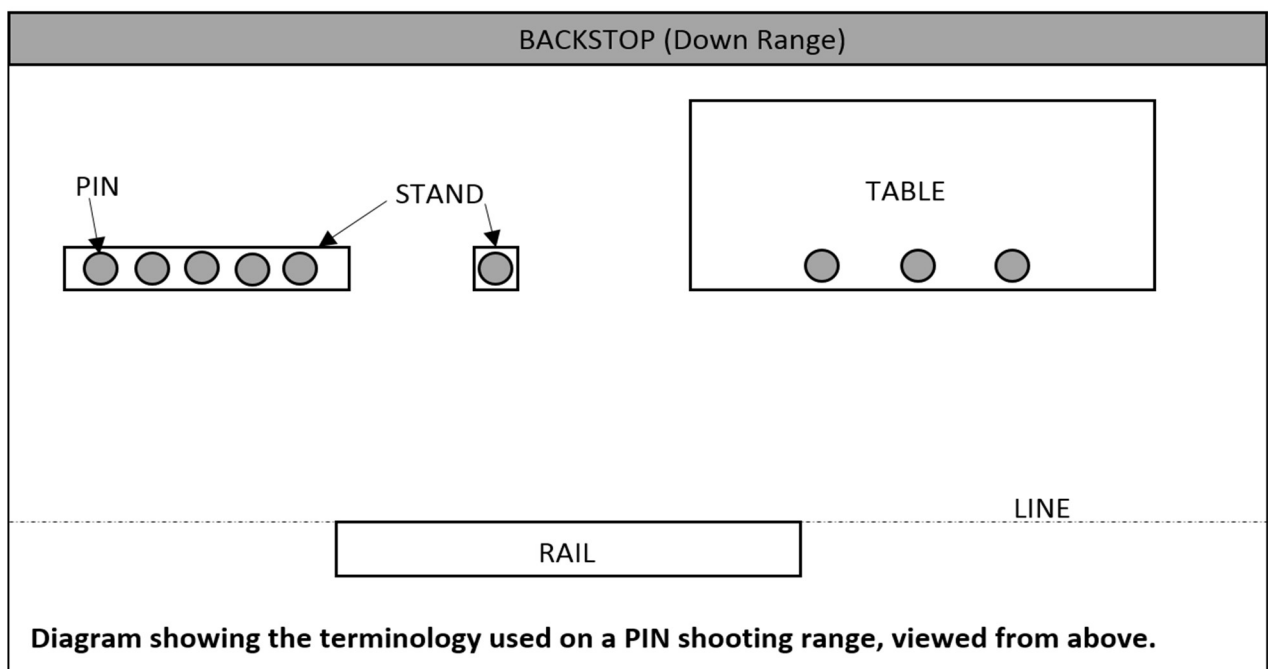

## 4. Rules & Procedures

### 4.1. Basic Firearm Safety Rules

- a. All firearms must be handled as if they are loaded at all times
- b. Firearms must be pointing in a safe direction at all times
- c. Shooters may not place their fingers on the trigger until they are on the target and ready to shoot
- d. Shooters must know their target and what is beyond it
- e. Shooters must never leave their firearm unattended and may not touch anyone else's firearm without permission
- f. Only ammunition that was specifically chambered for each firearm may be used
- g. Eye and ear protection must be used at all times, whether shooting, officiating or observing
- h. Range Officers have complete control of the range and their commands must be obeyed and respected at all times.
- i. Firearms may not be handled while under the influence of alcohol or drugs

### 4.2. Pin Shooting Safety Rules

- a. No loaded firearms shall be allowed behind the firing line, except by those persons appointed by the Range Master or Match Director to be carrying a loaded and holstered firearm. (See 4.4.f)
- b. Competitors, range officials, and spectators **must** unload any loaded carry gun at the designated unloading bay, usually at the entrance of any shooting range. Failure to comply may lead to disqualification from the match.
- c. Eye and ear protection shall be mandatory for competitors, spectators, and officials at all times when shooting is in progress. (See 4.4.a)
- d. All firearms shall be bagged (gun bag or gun box that can be closed and secured) until required, and may only be handled on the firing line with the Range Officer's instruction. Chambers or cylinders must be empty and detachable magazines removed. (See 4.4.c)
- e. Unbagged firearms are to be pointed downrange at all times (See 4.4.a), with the slide locked back or bolts open, ejection port facing up or cylinder open.
- f. Firearms of which the slides or bolts cannot be locked back, must have chamber flags inserted into the ejection port between strings. (See 4.4.a)
- g. All rifles and shotguns that are moved from the shooting line to the gun racks and that are on the gun rack for cooling must have chamber flags inserted. When moving from the line to the gun rack, the rifle or shotgun must be held with its barrel vertical up. (See 4.4.a)
- h. Any firearm moved from one firing position to another must be completely unloaded. (See 4.4.a)

- i. The angle made by the barrel of the firearm measured from the rail to the backstop, when viewed from above, may not exceed 45° (See 4.4.b). This will be referred to as the “45° rule”. Below is a diagram showing the range viewed from above, showing the 45° rule.

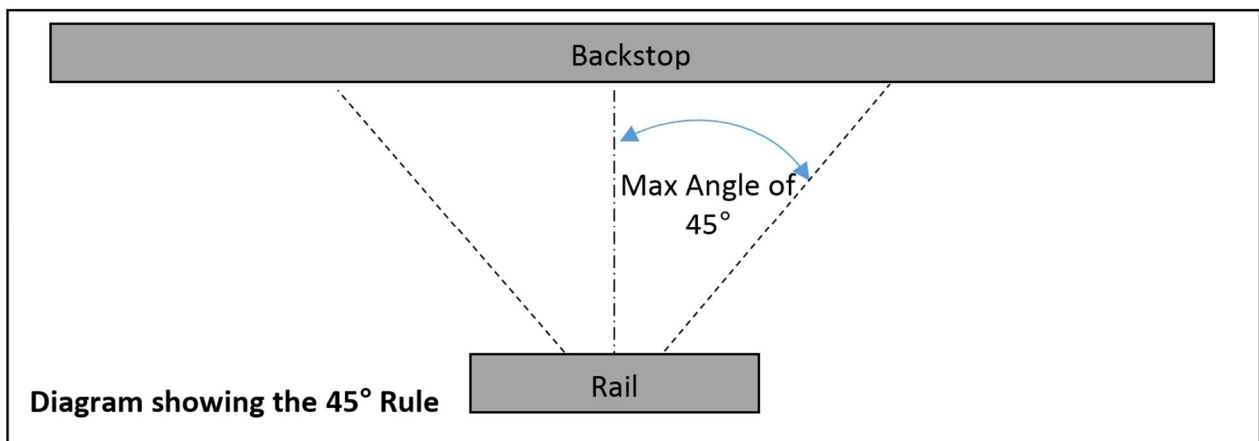

- j. The barrel of a loaded firearm must always clear the RAIL that the shooter is firing from. The maximum angle that the barrel of a loaded firearm can be raised up must not exceed the height of the backstop. For a revolver, with the cylinder open, the muzzle of the revolver may not pass the vertical up or vertical down position when performing a reload. See the diagram below. (See 4.4.b)
- k. A competitor who drops their firearm may not pick up the firearm themselves. It shall be the Safety Officer’s or Timer’s duty to prevent the competitor from doing so, and to alert the Range Officer to pick up and clear the firearm himself before taking any further action. (See 4.4.d)
- l. No rounds may be dropped into an open chamber of a pistol or self-loading rifle (SLR); all loading must be done via the magazine. (See 4.4.a)
- m. Metal piercing, incendiary, tracer or ammunition determined by the Range Officer or Match Director to be unsafe, are prohibited. (See 4.4.a)

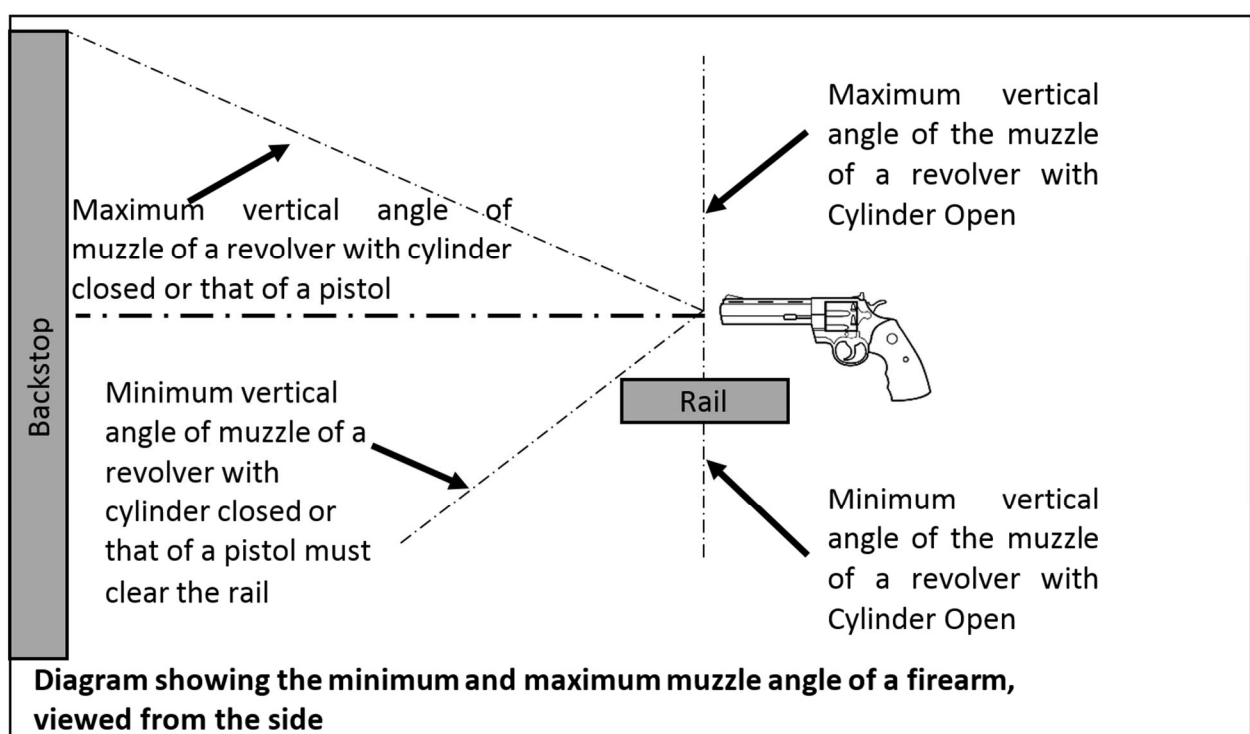

- n. Handloaded ammunition shall not exceed safe pressure levels. The Range Master has the discretion to stop any shooter from using ammunition that he deems to be unsafe.
- o. The Range Master has the right to request that competitors have ammunition tested that he suspects to be unsafe. Major and minor power factor for the appropriate calibre.
- p. The Shooter's trigger finger must be straight and visibly outside of the trigger guard at all times until the signal to commence fire is given and the firearm is pointed at the target. (See 4.4.a)
- q. Trigger shoes may not exceed the width of the trigger guard. If a firearm is deemed to violate this by the Range Master, the firearm will not be permitted to be used in the match.
- r. The hammer of a pistol or revolver may not be manually cocked, either fully or partially, prior to the start signal. Fingers must be clearly off the hammer of the firearm until the start signal has sounded. (See 4.4.g)
- s. Safety catches, where applicable, shall be engaged while in the ready position. (See 4.4.g)
- t. Ready conditions of firearms in a match shall be: (See 4.4.g)
  - i. Revolvers - hammer down.
  - ii. Single action only pistol - hammer cocked with safety on.
  - iii. Double action only pistol - hammer down with the safety off.
  - iv. Selective action pistol with the hammer down - safety off.
  - v. Selective action pistol with the hammer cocked - safety on.
- u. In the event that a firearm cannot be unloaded due to a mechanical failure, the Range Officer must make certain the firearm does not leave the firing line before the firearm is rendered safe by mechanical means, if possible, and then bagged. A way should be found, if possible, to preclude the firing pin access to a live cartridge.
- v. It is the duty of every shooter to ensure that their firearms are in good working order and that reloaded ammunition is checked for safe loads, chambering, high primers, etc. The shooter will forfeit scores for that string or event and may not demand a reshoot if their ammunition and/or weapon malfunctions.
- w. In the event of repeated malfunctions (a maximum of 3 per event) that delay the shoot, or provoke possible safety infringements, a shooter will be requested to make safe, bag the firearm, and leave the line. Once they have corrected the problem to the satisfaction of the Range Officer, they may continue the shoot at the sole discretion of the Range Officer. The shooter may use a standby firearm to continue that event.
- x. Any safety infringements by any person on the range must be brought to the attention of the Range Officer, Range Master, or the Match Director.
- y. Anyone may, and are obligated to, intervene directly on a safety infringement where there is a likelihood of an injury or in a life-threatening situation. Such incidents must be brought to the attention of the Range Office who will be obliged to take the necessary steps.
- z. The Range Master may ban any firearm deemed to be unsafe.

- aa. If a competitor is unable to finish a string due to injury or equipment malfunction, they shall raise their free hand and alert the officials as an indication of their predicament.
- bb. The practice of the ejection and catching of the ejected round in the air will be considered unsafe firearms handling (See 4.4.a). Competitors are prohibited from unloading pistols by cupping the weak hand over the ejection port to catch the ejected round.
- cc. Interfering with a competitor, physically or verbally, unless for safety reasons, will be considered unsportsmanlike behaviour. (See 4.4.g)
- dd. The Safety Officers shall be close enough to the shooter to be able to intervene in safety matters, but not too close so as to hinder the competitor. (See 4.4.q)
- ee. The leading edge of the rail shall constitute the firing line (See 3.h), and competitors may not cross this line before the range has been declared clear by the Range Officer **and** the instruction to reset the pins given. (See 4.4.a)
- ff. Pin setters may only go forward on the Range Officer's command. (See 4.4.a)
- gg. The distance between shooters shall not be less than 1,5 m, unless a partition is in place.
- hh. Non-shooters shall remain beyond the demarcated area. This does not apply to match officials and competitors that are officiating and participating in an event. (See 4.4.g)

### 4.3. Range Rules

- a. All Pin shooting events must take place under the direct control and supervision of a South African Pin Shooting Federation Certified Range Officer (RO) who must control all access to, and actions on, the shooting range. In the event of one not being available, they may be substituted by a qualified RO from another shooting discipline at club level only.
- b. A re-shoot can only be authorized under the following conditions:
  - i. if the shoot is stopped for safety reasons; or
  - ii. in the event of range equipment failure; or
  - iii. in the event of a tie.
- c. On elimination rounds, the Range Officer / Safety Officer will indicate the elimination of a shooter by a light tap on their shoulder.
- d. The time recorded by the officiating timekeepers shall be final, unless a dispute is declared, in which event the Match Director will resolve the issue. See 6.
- e. In the event of any dispute, the Range Master's decision will be final and they shall be in overall charge of all disciplines and actions on the range.
- f. Rules and regulations may be temporarily changed to suit the range at the Match Director's discretion, provided safety is not compromised. Due notice of changes shall be given prior to the event.
- g. Any person attending a pin shooting match shall be subject to the authority of the appointed Range Officer while on the range.

- h. Red clothing worn outwardly is reserved for Range Officers only as a means of easy identification.
- i. Appropriate dress and clothing must be worn i.e., closed shoes. All paramilitary dress, camouflage clothing, clothing supporting a particular political affiliation, clothing that may be deemed offensive or insulting is strongly discouraged. The match officials have the right to ask the offending person to remove or cover the item of clothing.
- j. Only paid-up SAPSF members in good standing may participate in any SAPSF sanctioned Provincial and National shoots.

#### 4.4. Disciplinary Offences

Occurrences that deviate from the norm and that require range or match officials' attention to be known as **INCIDENTS**. Incidents may have consequences for competitors, including:

**DISQUALIFICATION** (abbr. DQ)– it is suggested this term only be used when a competitor is banned from an entire match due to a serious safety infringement, dishonesty, or bad sportsmanship.

**PENALTY** (abbr. PTY) – the consequences to relatively minor incidents to be collectively known as PENALTIES.

**CAUTIONS** – issued by a Timer, Safety Officer or RO to pre-empt safety or rule transgressions by a competitor, this is reported to RO and recorded in the incident log at the discretion of the RO. A competitor can only receive one CAUTION for a transgression, after that they will receive a FORFEITURE for each subsequent transgression of that type.

**FORFEITURE** – An EVENT can be **FORFEITED** (no score for the entire event) for an ACCIDENTAL DISCHARGE (i.e. due to gun failure) that is not due to negligence by the competitor, or for another TRANSGRESSION by the competitor that is not a serious safety infringement or dishonesty. Serious offences will normally result in DISQUALIFICATION, not FORFEITURE. Some discretion may be allowed to the RO, but they must be consistent. More than one FORFEITURE in a single match, may lead to DISQUALIFICATION, depending on the circumstances.

Transgressions that require penalties are referred by the RO to The Range Master (RM), who is the only match official that can penalize a competitor, this being a FORFEITURE or DISQUALIFICATION. The RM decision is final. When a disqualification is issued, the RM must record the reasons for the disqualification, and the time and date of the incident and the Match Director must be notified as soon as possible in writing. Scores for a competitor who has received a disqualification must be deleted from match results.

Examples of Disciplinary Offences include, but are not limited to:

- a. A competitor who commits a safety infraction or any other prohibited activity during a match will be disqualified and will be prohibited from attempting any remaining events of the match. Examples of a safety infraction will include, but are not limited to:
  - Handling a firearm at any time except when in a designated Safety Area or when under the supervision of an RO.
  - Allowing the muzzle of a firearm to point up range.
  - Allowing the muzzle of a handgun to point at any part of the competitor's body.
  - Failure to keep the finger outside the trigger guard while clearing a malfunction.

- Handling live or dummy ammunition in a Safety Area.
  - Having a loaded firearm other than when specifically authorized by a Range Officer.
  - Crossing the firing line after the range is closed.
- b. Any shooter breaking the 45° rule or whom the Range Officer or the Timer or SO judge to be handling their weapon unsafely will be disqualified by the Range Master from the match.
  - c. Handling of firearms without the direct instruction from the RO will result in disqualification from the match.
  - d. The dropping of a firearm, whether loaded or unloaded, will be considered unsafe handling and will invoke disqualification from the match, unless it is the result of factors not under the control of the competitor.
  - e. Carrying a loaded, holstered firearm on the range without the Range Master's permission will result in the disqualification from the match.
  - f. Unsportsmanlike behaviour will invoke a CAUTION for the first incident and then FORFEITURE of that event thereafter. This will include, but are not limited to, performing an action that will give the shooter an advantage, such as dropping the safety or cocking the hammer before the start signal, and not adhering to the maximum number of rounds permitted for an Event.
  - g. Gross unsportsmanlike behaviour will invoke disqualification from the entire match. A competitor will be sanctioned for gross unsportsmanlike behaviour for, but not limited to, cheating, dishonesty, failing to comply with the reasonable directions of a Match Official, or any behaviour likely to bring the sport into disrepute. Arguing with the Range Officer and continuing to do so after one verbal warning, may be deemed gross unsportsmanlike behaviour at the discretion of the Range Master.
  - h. Handling of firearms on the line once the range has been declared clear will result in disqualification from the entire match.
  - i. Performing a reload of a firearm with the shooter's finger on the trigger or in the trigger guard will invoke a CAUTION for the first incident and then FORFEITURE of that event from thereafter.
  - j. A Negligent Discharge (ND) will result in disqualification for the entire match. A Negligent Discharge being the discharge of a round when the shooter was not aiming at a target and intending to discharge a round. An example of this is when a shooter is performing a reload with his finger on the trigger and during the reload the firearm discharges.
  - k. If the Accidental Discharge (AD) was a result of the shooter's equipment failure, the equipment will be banned from the competition and the competitor will forfeit that event's scores. An incident will only be deemed to be an Accidental Discharge if it was clear from the SO and/or Timer that the shooter had not performed an unsafe act and that equipment failure was the cause of the discharge.
  - l. A person that discharges their firearm after the command "Guns on the Rail" but before the start signal will be disqualified from the match, barring an accidental discharge.
  - m. No shooter shall be under the influence of alcohol, drugs or intoxicating matter. This will invoke disqualification from the match, and the competitor will be asked to leave the range.

- n. A Safety Officer or Timer failing to perform their duties will be subject to a CAUTION. In the case of negligence resulting in an unsafe condition, that Safety Officer and/or Timer may be subject to corrective action, at the discretion of the Range Master.
- o. Any competitor who verbally or physically threatens an RO, match official, another competitor or spectator, will be disqualified from the match and will be subject to disciplinary action.

## 4.5. Range Commands

The following range commands shall be used at all PIN shooting matches.

### A. "THE RANGE IS CLOSED"

Once this command has been given, no person is allowed in front of the firing line. See 4.4.a

### B. "SHOOTERS TO THE LINE"

The shooter will move to the shooting line, and await the instruction to unbag.

No persons other than the Shooter, Safety Officer, Time and Range Officers are now allowed in the firing area. This area will be clearly demarcated.

### C. "YOU MAY UNBAG YOUR FIREARMS AND SHOW CLEAR"

- i. No firearm may be unbagged without being under the supervision of the SO.
- ii. SO is to supervise the un-bagging of the firearm to ensure safety. (See 4.4.q.) Firearms are to be unbagged with the muzzle pointing towards the backstop.
- iii. SO is to inspect the firearm to confirm that the firearm is unloaded and that the shooter does not break the 45° rule. (See 4.4.b.)
- iv. When the firearm has been inspected by the SO the firearm may be sighted (may practice aim at targets) or be placed on the table with the slide locked back or the cylinder open until the next command is given.
- v. Pistols that do not have a slide lock must insert a chamber flag to indicate that the firearm is not loaded.
- vi. At no time may the shooter dry fire the firearm. (See 4.4.g.)

### D. "LOAD AND MAKE READY"

- i. Once this command is given, the Timer will raise a red flag or red clipboard to indicate that the Shooter is not ready.
- ii. Once the Shooter has loaded their firearm, the Timer will lower the red flag or red clipboard to indicate to the Range Officer that the Shooter is ready to proceed.
- iii. SO is to ensure that the safety is engaged where applicable, or the hammer is down in the case of revolvers once the Shooter has loaded.
- iv. The SO and Timer are to ensure that the Shooter's trigger finger is visibly, and clearly outside of the trigger guard. (See 4.2.p)
- v. The Shooter may aim at targets with the firearm with their trigger finger visibly and clearly outside of the trigger guard.
- vi. The Shooter has 30 seconds to load and make ready before the next command is given.

### E. "SHOOTERS ARE YOU READY?"

- i. If no indication to the contrary is given (all flags are down, see D.ii.), the Range Officer will accept that the Shooters are ready and issue the "SHOOTERS ARE YOU READY?" command.
- ii. If a flag goes up after the command, "SHOOTERS ARE YOU READY?", has been given, and the time had not run out (30s see 4.5.D.viii), the command "**STAND EASY**" will be given by the Range Officer. The RO is then to wait until the flag is lowered or the time

runs out. If the time runs out, and the flag is still up or is raised again, the RO is to ask the Safety Officer if it is a safety issue. If it is a safety issue then the safety issue must be resolved before restarting. If it is not a safety issue, then the RO is to continue and reissue the command "SHOOTERS ARE YOU READY?", and continue the shoot.

- iii. If there is a safety issue and the RO gives the "SHOOTERS, ARE YOU READY?" command, the Safety Officer is to shout out to the RO that there is a safety issue with the Shooter. The RO is to give the "**STAND EASY**" command and safety issue is to be resolved. Once the safety issue has been resolved the RO is to continue and reissue the command "SHOOTERS ARE YOU READY?", and continue the shoot.

#### F. "TIMERS ARE YOU READY?"

- i. If no indication to the contrary is given, the Range Officer will accept that the timers are ready and issue the "TIMERS, ARE YOU READY?" command.
- ii. If a flag goes up after "TIMERS, ARE YOU READY?" command has been given, the "**STAND EASY**" command will be given by the Range Officer. The RO is to ask the Safety Officer if it is a safety issue or range equipment failure. If it is a safety issue then the safety issue must be resolved before restarting with the "SHOOTERS ARE YOU READY?" command. If it is not a safety issue or range equipment failure then the RO is to continue and reissue the command "SHOOTERS ARE YOU READY?", and continue the shoot.
- iii. In the event that there is a safety issue and the RO gives the "TIMERS ARE YOU READY?" command, the Safety Officer is to shout out to the RO that there is a safety issue with the Shooter. The RO is then to give the "**STAND EASY**" command and the safety issue is to be resolved. Once the safety issue has been resolved, the RO is to continue and reissue the command "SHOOTERS ARE YOU READY?", and continue the shoot.

#### G. "GUNS ON THE RAIL"

- i. When this command has been given, the muzzle must extend over the rail, with part of the firearm touching the rail unless the event specifies otherwise.
- ii. No shooter may touch the hammer of their firearm. (See 4.4.g)
- iii. The start signal must sound between two to five seconds after the "GUNS ON THE RAIL" command has been given.
- iv. Should there be any reason to abort the start, the command "**STAND EASY**" will be given by the Range Officer. Once the situation has been resolved, the Range Officer will restart the exercise with the "**SHOOTERS ARE YOU READY?**" command and the countdown to the start signal.
- v. If for any reason anyone has to go forward past the shooting line all firearms must be unloaded and placed on the rail in the same condition as the "CEASEFIRE, UNLOAD AND SHOW CLEAR" condition. All competitors on the line must step back from the rail a minimum distance of 1 meter. This is done on the command of the RO.

#### H. START SIGNAL

Shooting commences after the start signal, which can be either one or more of the following: A buzzer, whistle, visual light indicator, flag, or a light single tap or touch from the Safety Officer. At this time the shooter can raise their firearm off the rail, cock the hammer if required, take aim and engage the targets in any order.

#### I. STOP SIGNAL

Shooting will stop immediately on the second signal, which can be either one or more of the following: A buzzer, whistle, visual light indicator or flag, or a light single tap or touch from the

Safety Officer. Shooting will cease immediately if the command **“CEASE FIRE”** is shouted (typically in the case of a safety issue arising).

**J. “CEASE FIRE, UNLOAD AND SHOW CLEAR”**

- i. The command “CEASE FIRE, UNLOAD AND SHOW CLEAR” is issued after the “STOP SIGNAL”.  
Safety Officer is to ensure:
- ii. That the firearm has been unloaded by visually inspecting the firearm. In the case of pistols, the magazine has to be removed, the chamber empty and the slide locked back. Pistols that do not have a slide lock must have a chamber flag inserted in the chamber. The practice of the ejection and catching of the ejected round in the air will be considered unsafe firearms handling. It is strongly encouraged that all cartridges should be ejected onto the ground or the rail. See 4.4.a.
- iii. In the case of a revolver, all spent shells or live rounds are ejected and cylinder open. In the case where two revolvers are used all live rounds may be partially ejected from the secondary revolver in order that the cylinder cannot close. The primary firearm (first firearm) must be totally empty. The second firearm, if fired, must also be emptied of all spent shells and all live rounds.
- iv. After the shooter has shown the SO that their firearm is clear, the SO is to acknowledge this with the response “IF CLEAR, HAMMER DOWN AND PLACE ON RAIL (OR BAG)”
- v. At no time may the shooter break the 45° rule or go beyond the vertical limits set, see Section 4.2.j.
- vi. Once a shooter has been declared “clear”, the shooter must place their firearm on the rail with the barrel pointing downrange. If pins have to be reset, the shooter must step back from the firing line by at least 1 meter. This is a visual check for the Range Officer to see that all shooters have been checked and declared “clear”.
- vii. Should there be further strings to be shot, and the shooter is to stay at the current rail then refer to paragraph “K” below.
- viii. Should there be further strings to be shot, and the shooter is to move to the next rail then refer to paragraph “L” below.
- ix. After the last string has been completed, the Range Officer will continue with paragraph “M”.

**K. “IF CLEAR, TAKE YOUR AMMUNITION AND MAGAZINES, AND STAND BACK”**

- i. The RO is to ensure that all competitors have moved 1 meter off the rail before declaring the range “clear” and moving on to paragraph “N” below.
- ii. SO is to assist the shooter, if they require it, with the removal of their ammunition and magazines.
- iii. It is not compulsory for the shooter to take their ammunition and magazines from the rail if the shooter is ready for the next string.

**L. “IF CLEAR, MOVE ACROSS”**

- i. The SO is to ensure that all firearms are unloaded and in the “MADE SAFE” (see J.iv. above) condition before the shooter moves to the next shooting position.
- ii. The SO is to assist the shooter, if they require it, with the moving of the shooter's ammunition and magazines.
- iii. When all shooters are in position the RO can resume the shoot with “LOAD AND MAKE READY” (See D. above)

**M. “IF GUN CLEAR, HAMMER DOWN, BAG: CONFIRM”**

- i. Once the SO is satisfied that the firearm has been unloaded, the shooter will drop the hammer, by depressing the trigger while pointing at the backstop, to confirm the firearm is empty.
- ii. After the shooter has shown the SO that their firearm is clear the SO is to acknowledge this with the response "IF CLEAR, HAMMER DOWN AND BAG".
- iii. The shooter will proceed to bag the firearm under the SO supervision.
- iv. After the shooter has bagged the firearm, the Shooter, SO and Timer are to step back at least one meter from the firing line so that the Range Officer can determine which firearms have not been bagged.
- v. The Range Officer will confirm that all firearms have been bagged before moving onto the "RANGE IS CLEAR. PIN SETTERS MAY GO FORWARD" command (see **N**).

**N. "RANGE IS CLEAR. PIN SETTERS MAY GO FORWARD"**

- i. Once the range has been declared clear, cases may be collected.
- ii. In the event that pins are being reset at the end of a string (firearms un-bagged), no person is allowed to be within 1 meter of the rail. Failure to adhere to this will result in CAUTIONS. See also 4.4.i.

**O. SAFETY CONDITION FOR EACH TYPE OF FIREARM**

- i. Single-action revolver: Cylinder empty and loading gate visibly open
- ii. Double-action revolver: First revolver: All cartridges ejected from the cylinder and cylinder visibly open.  
Second revolver. If not fired and there will be another string, all cartridges half ejected and cylinder open. If fired, all cartridges ejected and cylinder open.
- iii. Semi-auto pistol: Magazine removed, slide locked back and chamber visibly empty. If slide cannot lock back, chamber flag inserted.
- iv. Manual shotgun: Magazine empty, bolt assembly locked back and chamber flag inserted.
- v. Semi-auto shotgun: Magazine empty, bolt assembly locked back and chamber flag inserted.
- vi. Manual rifle: Magazine empty, bolt, lever, pump locked open and chamber flag inserted.
- vii. Semi-auto rifle: Magazine empty and/or removed, bolt locked back and chamber flag inserted.
- viii. In the case of any firearm that does not easily fit into any of the above categories, the safe condition of said firearm should be determined by the Range Officer, if needed in consultation with the shooter and / or other expert persons at the range. If no safe condition can be determined for the firearm, the Range Officer may ban its use.

## 4.6. Scoring of Timed Events

- a. Times are measured by persons appointed as the "Timer" and/or "SO", using stopwatches and / or an electronic timing system.
- b. There MUST be two timers (Timer & SO) for each competitor in the Legacy events at National matches and it is recommended also for Provincial matches. Both times must be recorded manually or electronically and averaged to obtain the competitor's time. In the event of one of the times clearly deviating, it must be determined by self-declaration whether either of the timers pressed early or late. The level of deviation that is acceptable is at the discretion of the RO, but as a guide a difference of 0,4s and more between the two times should be regarded as excessive. The self-declared deviating time will be discarded and the remaining time will stand. If it cannot be determined which is the deviating time, the competitor will re-shoot the string. In

the case of one of the timers not recording a valid time for any reason, the remaining time will stand.

- c. It is equally recommended that there are two timers for elective events at Provincial and National matches, with the same process followed as in b. above. Not having two timers will, however, not invalidate the events. It is equally recommended that there are two timers for all club events, but club matches may be still be conducted where this is not possible.
- d. Each String will be 40 seconds in duration. Each string time must be recorded to two decimal places, e.g. 24.15s
- e. In timed disciplines, the time of each competitor's string is measured from the beginning of the start signal, **to the time the last pin hits the ground**.
- f. In the event of a pin landing on another table, to the left or right of the one being shot at, it is to be counted as "on the ground". If this is the last pin to land on the table, the time must stop as the pin hits the table.
- g. Any pins that have been shot, but have not hit the ground at the end of the stop signal, are counted as being left on the table and are to be scored as Did Not Finish (DNF) + the number of pins that did not hit the ground (e.g. if 2 pins have not hit the ground then the recorded score is DNF+2).
- h. The calculation of a DNF + is as follows; total time is calculated as (time allowed for string e.g. 40 seconds) + 2 seconds per pin left on the table. Example: Where 3 pins are left: DNF + 3. Total time = 40 + (3x2) = 46 seconds.
- i. Where four strings are shot (at a National Championship) the average of the best three strings are calculated. This will constitute the competitor's time for the event.
- j. Where three strings are shot, the average of the best two strings is calculated. This will constitute the competitor's time for the event.
- k. At a National Match, four strings will be shot for each of the 5 Legacy Events and the worst time recorded for each event will be dropped. At a National Match for all other Events, a minimum of three strings will be shot and the worst time recorded will be dropped. For all other matches, three strings will be shot for all Events and the worst time recorded will be dropped. The format of the National Match must be clarified on the invitation and is at the discretion of the hosting Match Director.
- l. To calculate the results of an Event, the average times for every event are expressed as a percentage. This is calculated as follows: Percentage = (Fastest average time) / (Competitor's average time) x 100. Example: A competitor achieved an average of 20 s. The fastest average is 12 s. Result: 12 / 20 x 100 = 60%. (The winner achieves 100%).
- m. To calculate the aggregate result for a group of Events, the percentages of the competitor for the individual Events are added together. Then the score is again converted to a percentage, by dividing the competitor's total, by the highest total achieved, and multiplying by 100. Example: A competitor achieved 20%, 50%, 60%, 90% and 80% in the "Legacy Events". That adds up to a total of 300. The competitor with the highest total has a total of 400. Thus, the final result is 300 / 400 x 100 = 75%. (The winner's result is 400 / 400 x 100 = 100%).

- n. All Club, National League, Provincial and National shoot results must be recorded and submitted to SAPSF for record-keeping, and to serve as proof of participation for “Dedicated Sport Shooter Status” purposes.
- o. At Provincial and National matches all recorded times must be issued in hard copy and made available to participants for scrutiny before final rankings and results are calculated.
- p. Where the times achieved by competitors are in question, it will be the Match Director’s decision to order a reshoot.
- q. Any person altering or tampering with times or scores will be guilty of “gross unsportsmanlike behaviour” and subject to a disciplinary procedure. (See 4.4.h)
- r. For National League, Provincial and National shoots the final overall position of the shooters will be determined using the five disciplines in the “Legacy Events” Events as described in (k) above. These being Pin Gun, Stock Gun, Pin Revolver, Stock Revolver and the Nine Pin Tip over events. These are also referred to as the “Legacy Events”, referring to their status as the original events from the Second Chance Pin Shoots in the USA in the 1970’s.
- s. For National League, Provincial and National shoots the final overall Junior Under 14 positions will be determined using the following 3 (.22LR) events; Nine Pin Tip-over, Rimfire Handgun and the Rimfire Self-Loading Rifle.

#### 4.7. Scoring of Elimination Events

- a. Elimination matches can be held with 4, 8, 16, 32 or 64 competitors in the first heat (shootout).
- b. Standard set-up of tables will be the same as per respective events as described.
- c. If the range cannot accommodate all the competitors at once, the first (and subsequent) heats (shootouts) can be broken up into several shoots.
- d. Shooters compete against each other in pairs of two. The competitor who first clears his table will advance to the next level. The loser is eliminated.
- e. The format for the elimination contests will be as per the Annexure B.
- f. A “tapper”, who is an experienced competitor, will watch a pair of two competitors, and when the first competitor has cleared his table, will gently tap the loser on their back or shoulder, to indicate that they must stop shooting.
- g. There is no time limit; competitors will continue shooting until the first competitor of each pair has cleared the table.
- h. If a shooter is not present at the command “Shooters, are you ready?” the next highest placed shooter who is present will automatically advance up the final positions for the elimination contests only and may compete in the eliminations contest. If a substitute competitor is not available, the remaining shooter will advance unopposed to the next round.

#### 4.8. Team Rules

- a. A team will consist of four members and each member must be specified before the start of the competition, with the best three scores to count towards the team total score. Any team member

who has to withdraw due to injury or illness may be replaced by a pre nominated reserve team member.

- b. In the case of a team member being disqualified from the match, the team's score for that member shall be zero.
- c. In the case that a team member is disqualified from an event they shall forfeit all scores for that event.
- d. Predetermined provincial teams as selected by each province will be eligible for team awards. Other teams, at the discretion of the match organizers, may be fielded for interprovincial matches, but will not be eligible for team awards.
- e. A team member may only represent the SAPSF province in which they reside, unless authorized by the SAPSF Executive Committee to represent another province.
- f. Teams made up exclusively of ladies may shoot against other ladies' teams for team awards; however, they will be eligible for team awards in another team at the same time.
- g. There must be a minimum of two teams in each category to qualify for team prizes or medals. In the event of two teams competing for team prizes or medals, the winning team will be awarded "gold" medals. In the event of three teams competing for team medals or prizes, the winning team will be awarded "gold" medals and the second team will be awarded "silver" medals. In the event of four or more teams, the winning team will be awarded "gold" medals, the second team will be awarded "silver" medals and the third team will be awarded "bronze" medals. This will apply to all categories. This will not apply to ladies and junior teams, in order to encourage participation.
- h. The above rule will also apply to individual disciplines.
- i. Every province will submit to SAPSF the provincial teams to compete in the Nationals prior to the event taking place, before the closing date of entry to the event. The teams may be changed due to illness and other legitimate reasons. This information must be available to all participating provinces and each province will be required to send at least one team to any National shoot, unless by prior arrangement with SAPSF, for which the reasons would have to be submitted and deemed to be valid.
- j. The Team score will be determined by their aggregated percentages of the five Legacy events. The Team with the highest aggregate score will be awarded first place.

#### 4.9. Age Categories

- a. Junior Under 14 Category <14 years old
- b. Junior Under 19 Category 14 to 18 years old
- c. Open Category 19 to 49 years old
- d. Senior Category 50 to 59 years old
- e. Veteran Category 60 to 69 years old
- f. Masters Category 70 and above

The age of the competitor, on the day that the SAPSF membership year commences (1 January), will determine his or her category for the rest of that calendar year.

## 4.10. Range Set-up

- a. A safe range shall constitute a range with:
  - i. Clearly defined danger area demarcated by red markers;
  - ii. Containment of directed shots;
  - iii. Good spectator control;
  - iv. A clearly demarcated unloading bay;
  - v. A design or layout where stray shots may cause no danger;
  - vi. A Safety area for firearm maintenance, NO AMMUNITION, snap-caps, blanks etc. will be permitted in the Safety area.
  - vii. A firearm that cannot be cleared safely on the line is to be bagged.
- b. The range is in compliance with the Occupational Health and Safety Act (OHAS).
- c. The range shall have a backstop and side screens conforming to at least the minimum requirements established by the appropriate authorities for shooting ranges.
- d. The firing points and the rail shall be suitably constructed to adequately and safely meet the requirements of the disciplines that are to be shot, subject to Annexure as per approval of the SAPSF Executive Committee.
- e. A range must have a safe area where shooters may handle and maintain their firearm(s). NO AMMUNITION, snap caps, blanks etc. will be permitted in the Safety area. (See 4.4.a)

## 5. Match Management

### 5.1. Match Director ("MD")

The duties of the Match Director are to:

- i. Handle overall match administration including squadding.
- ii. Scheduling, range setup, the coordination of all support staff and the provision of services.
- iii. His authority and decisions will prevail with regard to all matters, except in respect of matters in these rules which are the domain of the Range Master.
- iv. If a shooter has been disqualified from an event or match, the Match Director is to notify the administrative staff performing the scoring of this in writing.

The Match Director is appointed by the host organization and works with the Range Master. The host organization must, prior to the commencement of a match, appoint a Match Director and inform the shooters no later than at the safety briefing that is given on the first day of the match.

### 5.2. Range Master ("RM")

The duties of the Range Master are to:

- i. Be the primary authority over all persons and activities in the match are under his control.
- ii. Oversee all Range Officers, Safety Officers, Timers, and Shooters.
- iii. Oversee the fair, correct and consistent application of these rules.
- iv. Give the safety briefing that is given on the first day of the match.
- v. Oversee that the range and match are in compliance with Occupational Health and Safety (OHAS).
- vi. The Range Master is responsible for any disciplinary action taken and is assisted by two designated advisors. These advisors are appointed at the beginning of the match and are selected from the visiting provinces, if applicable.
- vii. The Range Master will be responsible for notifying the competitor of any disciplinary action taken.
- viii. Document all safety infringements, disciplinary action taken, and for provincial and national matches, submit this documentation to SAPSF.
- ix. Notify the Match Director, in writing, that disciplinary action has been taken. This is to include the shooter's full name, club number, the offence and the action taken.
- x. Issue range commands when on duty overseeing an event.

The Range Master is under the authority of the Match Director and is appointed by the Match Director.

### 5.3. Range Officer ("RO")

The duties of the Range Officer are to:

- i. Issue range commands.
- ii. Oversee competitor compliance with the event rules.
- iii. Monitor safe competitor action.
- iv. Oversee all Safety Officers and Timers that are on the line.
- v. Responsible for calling for a reshoot.
- vi. Report transgressions and recommend disciplinary actions against transgressing competitors to the Range Master
- vii. The RO is responsible for informing the administrative staff running the timing system that a reshoot has been authorized.

The match ROs are under the authority of the Range Master and are appointed by the Match Director with consultation with the Range Master.

#### 5.4. Safety Officer (“SO”)

The duties of the Safety Officer are to:

- i. Monitor the safety of the shooter on the line.
- ii. Notify the RO if there is a safety issue
- iii. Oversee competitor compliance with the event rules.
- iv. Time the string times for the shooter.
- v. Is responsible for overseeing the unbagging and showing that the firearm is clear at the start of an event, as well as bagging at the end of the event.
- vi. If required, a light single tap on the shooter's shoulder, signalling the start and stop of the string.
- vii. Is responsible for overseeing that the firearm is clear between the strings.
- viii. Instruct the Timer to raise the flag if there is a safety issue.
- ix. Resetting the pins after a string.

The SO is under the authority of the Range Master and Range Officer.

#### 5.5. Timer

The duties of the Timer are to:

- i. Monitor the safety of the shooter on the line.
- ii. Notify the RO if there is a safety issue.
- iii. Oversee competitor compliance with the event rules.
- iv. Time and record the string times for the shooter.
- v. To indicate that the shooter is not ready by holding up a flag.
- vi. Resetting the pins after a string

The Timer is under the authority of the Range Master and Range Officer.

Note that, of the three competitors that are shooting an Event, the SO will be the next shooter on the line and the Timer will be the shooter after that. In this way, the position of SO and Timer will be rotated throughout the Event. If there is a clear case that an individual cannot perform the task of the SO then, with permission from the RO, that competitor will only perform the duties of the Timer.

## 6. Ammunition Classification and Definitions

The RO has the right to restrict the use of any firearm and/or ammunition that does not fall within the categories below or if it is deemed to be a safety risk.

### 6.1. Handgun Calibre Cartridge

Handgun Calibre Cartridges are for current purposes defined to be centrefire cartridges that can be fired from a pistol or revolver. This is restricted to one round being discharged on a single activation of the trigger. Typical Handgun Calibre Cartridges are, but are not restricted to, .380, 9 mm P, 40 S&W, 357 Sig, 45 ACP, 38 Spl, 357 Mag, and 44 Mag. The match organizers have the right to restrict a handgun/ammunition if they deem it to not fall within this category e.g. 454 Casull, 500 S&W Magnum.

### 6.2. Rifle Cartridge Calibre Classification Light Rifle:

Centre fire rifle calibres .223 Rem and below, 7,62x39mm and 300 Blk are **Light Rifle**.

### 6.3. Rifle Cartridge Calibre Classification Rifle:

Any centre fire rifle calibre not mentioned in 6.2. above is classified as **Rifle** until decided otherwise.

### 6.4. Shotgun Calibre Shell

A Shotgun Calibre Shell fires a number of small spherical lead pellets, called shot. Shotguns with a bore of 12-gauge, 16-gauge, 20-gauge and .410 may be used in the shotgun PIN events. The shot size that can be used for a PIN shooting event is between and including a No.7,5 to LG. The hosting club/province has the right to mandate further restrictions on the shot size if deemed necessary due to local circumstances. No magnum rounds may be used in any of the PIN events.

### 6.5. Grandfather Clause

The continued use of firearms that were eligible for events under the immediately preceding rule book, but now became ineligible under this new rule book, is hereby mandated. This grandfather clause will apply for a period of three years after the ratification of this new rule book. It is foreseen that it will apply especially for firearms that were previously deemed to qualify for Rifle Cartridge events, but under this Rule Book qualify instead for Light Rifle Cartridge events, i.e. firearms shooting the 7,62 x 39 cartridge.

## 7. Firearm Classification and Definitions

### 7.1. Pistol

A “pistol” by definition shall mean a self-loading handgun in single or double action which is magazine fed. The magazine must be contained within the grip of the pistol, excluding .22 pistols. The pistol is chambered in a handgun calibre cartridge, see Ammunition Classification, 6.1 above.

Slide-mounted optical sights are allowed on all pistols, except .22 Rim fire pistols where barrel- or frame-mounted optical sights are allowed.

### 7.2. Revolver

A “Revolver” by definition shall mean a handgun incorporating a revolving cylinder, in either single or double action. Automatic or Self-loading revolvers with retractable slides are prohibited in this Division. The revolver is chambered in a handgun calibre cartridge, see Ammunition Classification, 6.1 above. Optical sights are allowed on all revolvers.

### 7.3. Optical Sight

An “optical sight” by definition shall mean a sighting device that incorporates or uses a lens or lenses. That includes red-dot sights, reflex-sights, holographic sights, telescopes and any other similar devices. Fibre optic inserts are not classified as optical sights.

Laser sights are not allowed to be switched on at any time during a match.

### 7.4. Backup Gun

A shooter is permitted a backup firearm of the same or essentially similar configuration, for each event that they take part in. This backup firearm will be permitted to be used in a match after receiving permission from the RO. Equipment failure due to the nature of the sport (powerful loads, the large number of rounds fired) is a standard occurrence. Also, the more competitive the shooter, the more stress is placed on the firearm due to training and participation in disciplines, thus the breakdown rate increases proportionately.

## 8. Format for the Pin Shooting Events

### 8.1. Handgun and Shotgun Events

**Table 1 – Summary of Pin Shooting Events: Handgun and Shotgun (shot at 7,6m)**

Events for Clubs, National Postal Leagues, Provincial and National Championship competitions.

Pins Set at 7.6m	Table Layout			Load Condition		Notes
	Number of pins	Number of pins on top table	Number of pins on bottom table	Maximum number of rounds loaded on start	Maximum number of rounds loaded after reload	
Pin Gun	5	2	3	8	8	No second firearms permitted.
Stock Gun	8	4	4	8	8	Compensators not permitted, revolvers & speed loaders allowed, also a second fire arm.
9 Pin Tip-Over	9		9	Max	Max	Any centre fire pistol.
Pin Revolver	5	2	3	8	8	Speed loader etc. permitted.
Stock Revolver	8	4	4	6	6	Forced reload, no speed reloader or moon clips, no second revolver.
Pocket Pistol	5		5	7	7	
Snub nosed Revolver	5		5	6	6	
22 Rimfire Handgun	5*		5*	8	8	*Pin Heads
Space Gun	9		9	Max	Max	
Shotgun Manual Action	5	2	3	3	Max	
Shotgun Self-Loading	5	2	3	3	Max	
Shotgun Open	5	2	3	Max	Max	

## 8.2. Rifle and Carbine Events

**Table 2 – Summary of Pin Shooting Events: Rifle and Carbine (shot at between 15m to 100m)**

Rifle and Carbine events	Table Layout			Load Condition		Notes
	Number of pins	Number of pins front position	Number of pins rear position	Maximum number of rounds loaded on start	Maximum number of rounds loaded after reload	
Light Rifle Manual Action	5	3 at 50m	2 at 100m	5	5	Bi-pods and Other permitted
Light Rifle Self-Loading	8	5 at 50m	3 at 100m	Max	Max	Bi-pods and Other permitted
Rifle Manual Action	5	3 at 50m	2 at 100m	5	5	Bi-pods and Other permitted
Rifle Self-Loading	8	5 at 50m	3 at 100m	Max	Max	Bi-pods and Other permitted
Rimfire Rifle Manual Action	5	3 at 15m	2 at 30m	10	10	
Rimfire Rifle Self-Loading	8	4 at 15m	4 at 30m	Max	Max	
Carbine Manual Action	5	3 at 15m	2 at 30m	10	10	
Carbine Self-Loading	8	4 at 15m	4 at 30m	Max	Max	

## 8.3. General Table and Pin Setup for Rifle and Carbine Events

Note: Table and pin setup for handgun and shotgun events is dealt with under the description of the events in Appendix A. So is specific table and pin setup for rifle and carbine events.

For all the Rifle and Carbine events, the following setup is common and is required. At National and Provincial matches this format is required to be followed. If a club cannot adhere to this range setup, then they are to notify all competitors two months prior to the match of the change in range layout. The two months' notice is to give competitors the opportunity to practice the non-standard layout.

- i. The pins are to be spaced 0.38m apart when viewed from the front.

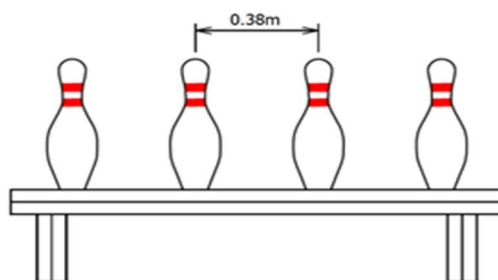

- ii. The maximum separation between pins, when viewed from the top, should not exceed 1m.
- iii. The spacing between the front and rear set of pins should not exceed 2m. When viewed from the firing line the front and rear set on pins should be clearly separated.

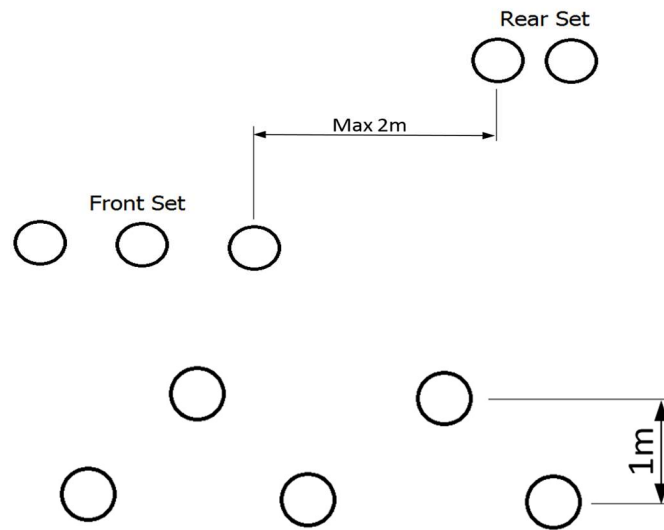

- iv. The rear set of pins can be placed on the left or right of the front set. Note that if the rear set of pins is placed on the left of the front set, then all of the rear sets of pins on that range must be placed on the left. This is to ensure consistency between the different shooting stations on that range.
- v. The front and rear sets of pins should not overlap when viewed from the firing line.

# Appendix A. Event Rules and Setup

## Legacy Handgun Events:

All Handgun events are shot from 7.6m

### A.1. Pin Gun Event - Five Pins

#### a. Firearm Description.

- i. A “pin gun” by definition shall mean a handgun, which is a pistol or revolver and is chambered in a handgun calibre cartridge (see Ammunition Classification, 6.1 above).
- ii. A “pin gun” may have virtually any aftermarket addition including optical sights (slide mounted on pistols), fibre optic inserts or open sights, screw-on, bolt-on or clip-on barrel weights and compensators. Laser sights should be switched off. The decision to allow weapons that do not easily fit into the above description, into a “pin gun” event, falls on the Match Director.
- iii. Recommended calibres – Revolvers: .357 Magnum to .44 Mag and Pistols: 40 S&W to 45 ACP. 9mmP calibre is not permitted in the Pin Gun Discipline at National or Provincial matches. This may be set aside at the discretion of the host Match Director.

#### b. Table Layout (front view and side view)

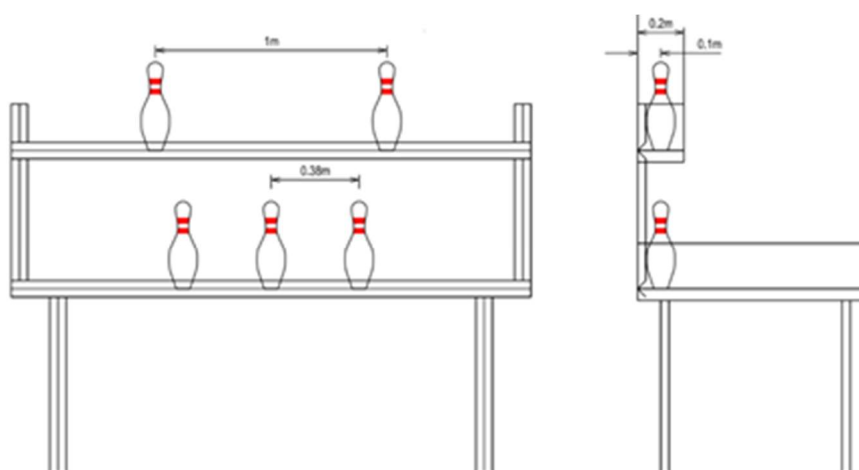

#### c. Event Rules

- i. Any 1 pistol or 1 revolver may be used.
- ii. Second firearm not permitted.
- iii. A maximum of EIGHT ROUNDS may be loaded before the start signal.
- iv. Re-loading of a firearm within the allotted time is allowed, provided no more than eight rounds are in the firearm at any one time. Full moon clips, half-moon clips or speed loaders may be used.
- v. If more than eight rounds are loaded in a pistol, but not more than EIGHT shots are discharged before a reload, the competitor will receive a verbal warning.
- vi. If more than EIGHT rounds are discharged before a re-load, that will result in the forfeiture of that string.

## A.2. Stock Gun Event - Eight Pins

### a. Firearm Description.

- i. A “stock gun” by definition shall mean a handgun, which is a pistol or revolver and is chambered in a handgun calibre cartridge (see Ammunition Classification, 6.1 above.)
- ii. No form of compensated pistols (including but not limited to chamber compensators, barrel ports or muzzle brakes) will be allowed to be used in the Stock Gun event. Pistols that have been factory built with compensators, barrel ports and/or muzzle brakes (i.e. over the counter purchase with no after-market add-on features) will not be allowed in this discipline.
- iii. Revolvers that have factory fitted compensator are permitted to be used in this event, examples of these are the Taurus 608 and Smith & Wesson 627 V-COMP, with the factory fitted compensator. The Match Director has the final say regarding the eligibility of any compensated revolver that is to be used in this event. Note: The origin of this provision (compensators allowed for revolvers, but not pistols) is historical and is to be found in the use of ported eight-shot revolvers, notably the Taurus 608. The rationale is that in order for these ports to be effective, very powerful loads have to be used, thus levelling the playing field with non-ported pistols).
- iv. Recommended calibres – Revolvers: .357 Magnum to 44 Mag and Pistols: 40 S&W, 10mm to 45 ACP. 9mmP calibre is not permitted in the Stock Gun Discipline at Nationals and Provincial matches. This can be waived at the discretion of the host Match Director.
- v. Optical sights (slide mounted on pistols), open sights and fibre optic inserts are allowed. Lasers must be switched off.
- vi. The decision to allow firearms that do not easily fit the above description, into a “stock gun” event, falls on the Range Master on duty for that particular match. Any disputed firearms must be brought to the Chief Range Officer’s attention prior to match commencement and any decision made before shooting commences will be final. SAPSF can make a final and binding rule regarding disputed firearms.

### a. Table Layout (front view and side view)

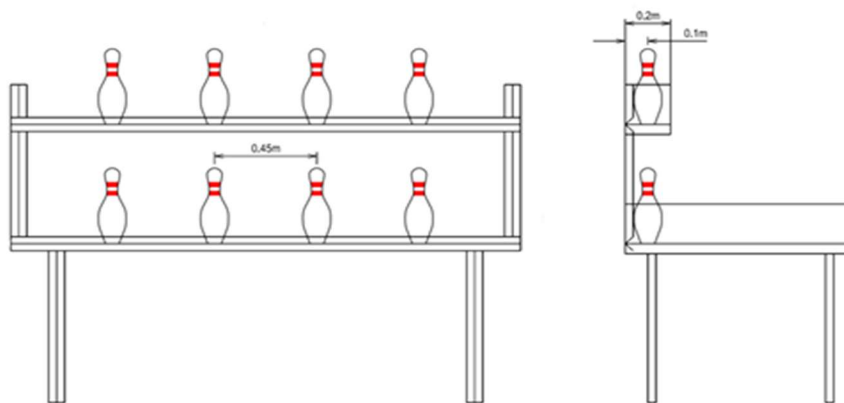

### b. Event Rules

- i. Any 2 pistols, 2 revolvers or one pistol and one revolver may be used.
- ii. A maximum of EIGHT rounds may be loaded in each of the firearms before the start signal. Safeties must be engaged on all pistols. Full moon clips or half-moon clips or speed loaders may be used.
- iii. A maximum of EIGHT rounds in each firearm at any time after the first reload.
- iv. If more than eight rounds are loaded in a pistol, but not more than EIGHT shots are discharged before a reload, the competitor will receive a verbal warning.
- v. If more than EIGHT rounds are discharged before a re-load, that will result in the forfeiture of that string.

### A.3. Nine Pin Tip-Over Event – Nine Pins

#### a. Firearm Description.

- i. A “Nine Pin Tip-Over Handgun” by definition shall mean any centre-fire self-loading pistol which is chambered in a handgun calibre cartridge of minimum 9mmP.
- ii. A “Nine Pin Tip-Over Handgun” may have virtually any aftermarket addition, including screw-on, bolt-on or clip-on barrel weights, but only one of the following:
  - a. a compensator; or
  - b. slide mounted optical sights (any laser sight must be switched off).
- iii. A “Nine Pin Tip-Over Handgun” if it has a Compensator and a slide mount optic sight will not be Allowed in this event and will fall under Space Gun Event.
- iv. A “Nine Pin Tip-Over Handgun” may not have frame mounted optical sights.
- v. The decision to allow firearms that do not easily fit into the above description, into the “Nine Pin Tip-Over Handgun” event, falls on the Match Director.
- vi. Junior’s under-14 years old may use a .22 Rimfire handgun and are allowed to shoot from dead rest if preferred. Their scores will only be formally recognized against other Junior Under 14’s, although at club level this may be waived to encourage junior shooters.

#### b. Table Layout (front view and side view)

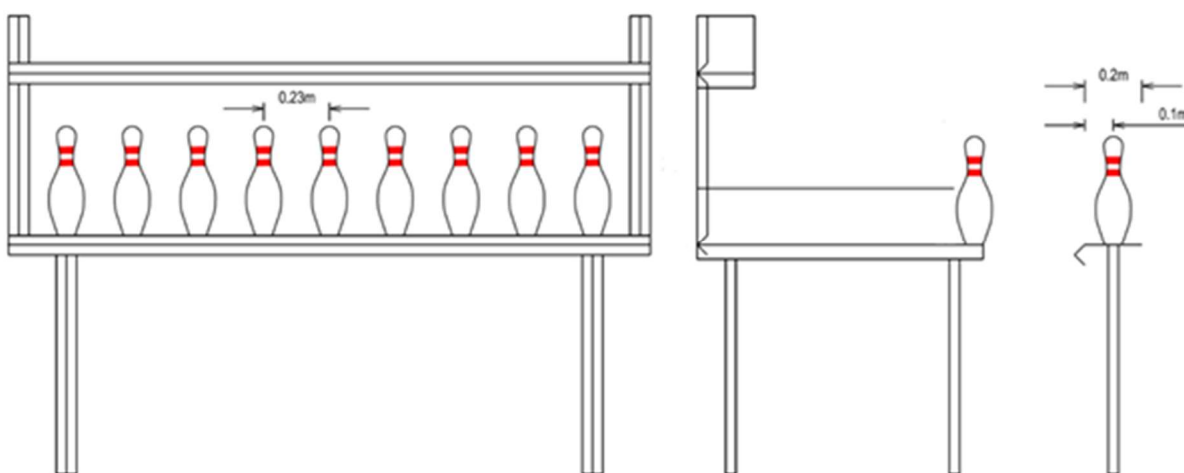

#### c. Event Rules

- i. No restriction on loading capacity of the magazine(s). Extended magazines are allowed.
- ii. Reloading of the firearm within the allotted time is allowed.

## A.4. Pin Revolver Event - Five Pin

### a. Firearm Description.

- i. A "pin revolver" by definition shall mean a handgun, which is a revolver and is chambered in a handgun calibre cartridge, see Ammunition Classification, 6.1 above. Recommended Calibres: .357 Magnum to .44 Mag.
- ii. A "pin revolver" may have virtually any after-market addition, including optical sights. Laser sights should be switched off. and/or laser sights. Therefore screw-on, bolt-on or clip-on barrel weights and/or compensators are allowed in the "pin revolver" discipline, although the decision to allow weapons that do not easily fit into the above description in a "pin" revolver event falls on the Chief Range Officer.

### b. Table Layout (front view and side view)

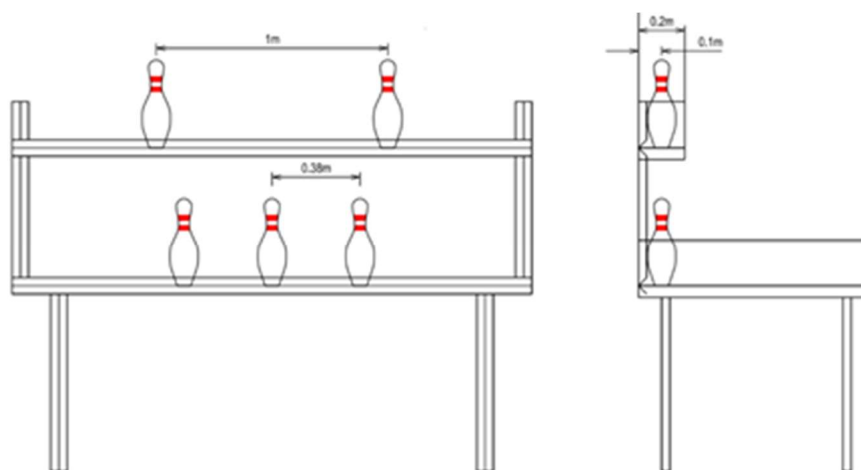

### c. Event Rules

- i. Any centre-fire revolver (single or double action), six-shot, seven-shot or eight-shot revolver, fully loaded may be used.
- ii. A maximum of EIGHT ROUNDS may be loaded before the start signal.
- iii. Re-loading of a firearm within the allotted time is allowed, provided no more than eight rounds are in the firearm at any one time. Full moon clips, half-moon clips or speed loaders may be used.
- iv. Only one revolver may be used.

## A.5. Stock Revolver Event - Eight Pin

### a. Firearm Description.

- i. A “stock revolver” by definition shall mean a 6, 7 and 8 shot factory-original mass-produced revolver, including Taurus 608 and Smith & Wesson 627 VCOMP revolvers, which is chambered in a handgun calibre cartridge (see Ammunition Classification, 6.1 above.). Revolvers with factory porting or factory fitted compensators will be allowed. Recommended Calibres: .357 Magnum to .44 Mag.
- ii. The following modifications are allowed: Replacement grips, firing mechanism parts, open sights and relief cuts to the cylinder.
- iii. Optical sights, Open sights and fibre optic inserts are allowed. Laser sights are to be switched off.
- iv. The decision to allow firearms that do not easily fit the above description, into a “stock” revolver event, falls on the Range Master on duty for that particular match. Any disputed firearms must be brought to the Chief Range Officer’s attention prior to match commencement and any decision made before shooting commences will be final. SAPSF can make a final and binding rule regarding disputed firearms.

### b. Table Layout (front view and side view)

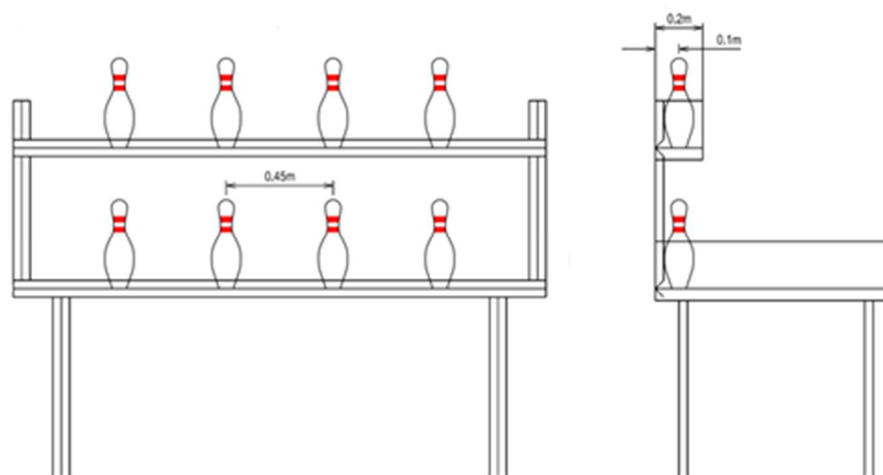

### c. Event Rules

- i. A maximum of SIX ROUNDS may be loaded before the start signal.
- ii. A second revolver is not allowed.
- iii. A compulsory manual reload is required in the stock revolver discipline. A reload is defined as ejecting all shells from the firearm; where after a maximum of SIX ROUNDS may be loaded.
- iv. NO speed loaders, NO half-moon clips and NO full moon clips may be used. In revolvers that use rimless ammunition, no more than 2 (two) cartridges may be held together by clips.
- v. In the event that the shooter manages to clear the table with 6 shots, the shooter has to reload and fire a shot over the table in order to stop the time
- vi. If more than six rounds are loaded, but no shot is fired, the competitor will receive a verbal warning and will remove the excess rounds.
- vii. If more than SIX rounds are discharged between reloads, that will result in the forfeiture of that string.

## Elective Handgun Events:

### A.6. Pocket Pistol Event - Five Pin

#### a. Firearm Description.

- i. A “pocket pistol” by definition shall mean a centre-fire pistol with a barrel length including chamber of less than 3.875” (99mm) in length. This length will be determined, from breech face to the furthest forward part of the firearm. A “pocket pistol” is chambered in a handgun calibre cartridge.
- ii. Open sights, fibre optic inserts and slide-mounted optical sights allowed. Laser devices are to be switched off.

#### a. Table Layout (front view and side view)

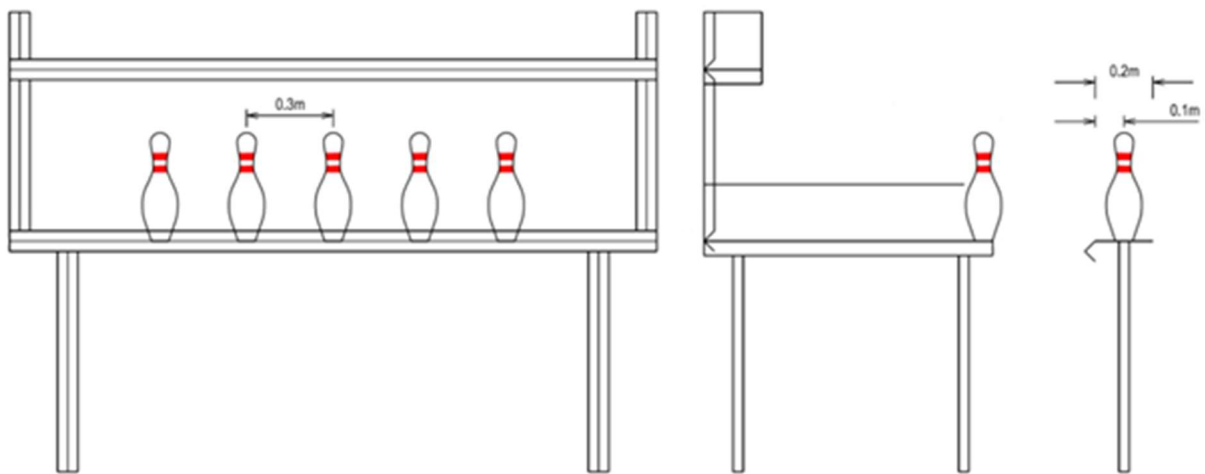

#### b. Event Rules

- i. Recommended calibres:  $\geq .32 / 7,65\text{mm}$ .
- ii. A maximum of SEVEN ROUNDS may be loaded before the start signal. Re-loading of a firearm within the allotted time is allowed, provided no more than SEVEN ROUNDS are in the firearm at any one time.
- iii. Re-loading can be done with pre-loaded magazines.

## A.7. Snubby Revolver - Five Pins

### a. Firearm Description.

- i. A “Snubby Revolver” by definition shall mean a centre fire revolver with a barrel not exceeding 3” (76.2mm) in length. Barrel length will be measured from the Forcing Cone, to the furthest forward part of the firearm. This measurement will include the forcing cone and any muzzle appendages or ports and chambers. A “Snubby Revolver” is chambered in a handgun calibre cartridge, see Ammunition Classification, 6.1 above.
- ii. Open sights, fibre optic inserts and optical sights allowed. Laser devices are to be switched off or disengaged.

### b. Table Layout (front view and side view)

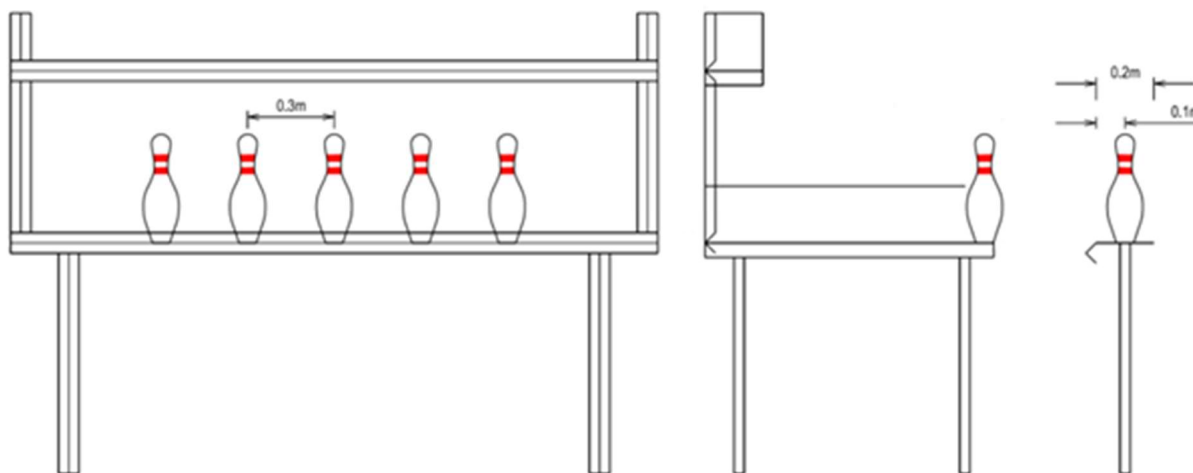

### c. Event Rules

- i. Recommended calibres: 38spl / 357 mag
- ii. The firearm may be loaded to maximum capacity.
- iii. Re-loading can be done with speed loaders, full moon clips or half-moon clips.

## A.8. Rimfire Handgun Event – Five Pins

### a. Firearm Description.

- i. A “22 Rimfire Handgun” by definition shall mean a .22 handgun (revolver or pistol, excluding single shot) with no limitation on barrel length.
- ii. Optical sights are allowed. Open sights and fibre optic inserts are allowed.

### b. Table Layout (front view and side view)

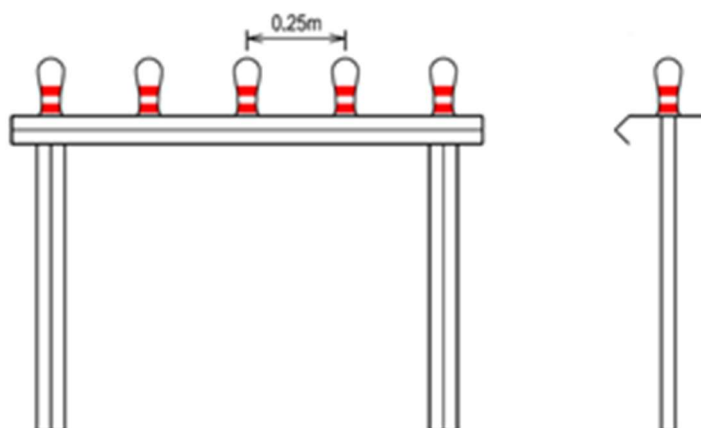

### c. Event Rules

- i. A maximum of EIGHT ROUNDS may be loaded at any time.
- ii. Re-loading can be done with speed loaders or magazines.
- iii. Junior Under-14 competitors will be allowed to shoot from dead-rest. Their score will only be formally recognized against other juniors, although at club level this may be waived to encourage junior shooters.

## A.9. Space Gun Event - Nine Pins

### a. Firearm Description.

- i. A "Space Gun" by definition shall mean a pistol or revolver, any modifications allowed, except stocks and rests. A "Space Gun" is chambered in a handgun calibre cartridge, see Ammunition Classification, 7.1 above.
- ii. Any centre-fire self-loading pistol or revolver may be used.
- iii. Optical sights are allowed. Open sights and fibre optic inserts are allowed.
- iv. Compensators, weights and other performance-enhancing attachments are allowed.

### b. Table Layout (front view and side view)

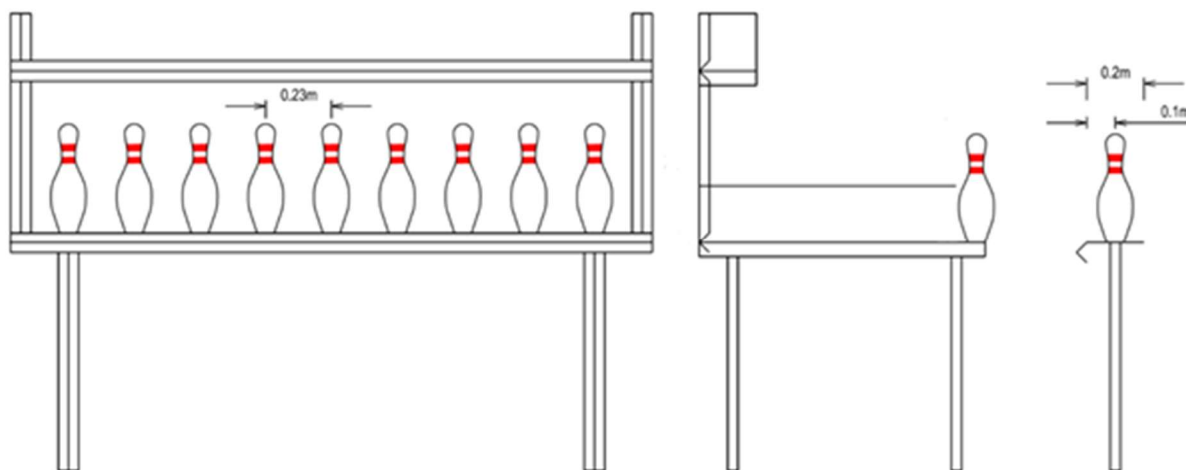

### c. Event Rules

- i. Any and all modifications allowed, as long as the weapon is still a handgun. That includes any type of optical or other sight, compensators, weights etc.
- ii. No restriction on loading capacity of the magazine(s).
- iii. Extended magazines are allowed.
- iv. Re-loading of firearm within the allotted time is allowed.
- v. The rules and / or table layout may be changed by the Match Director, to a 5-pin, 8-pin, or any other suitable layout, with adequate prior notice to competitors. Adequate prior notice is considered to be at the invitation to the match.

## Elective Rimfire Rifle Events:

### A.10. Rimfire Rifle Manual Event - Five Pins

#### a. Firearm Description.

- i. A "Rimfire Rifle Manual" by definition shall mean a manually operated .22 Rimfire Rifle. This will include bolt-action, lever-action and pump-actions, etc.
  - ii. Optical sights, open sights and silencers are allowed.
- b. Table Layout** (front view and side view)

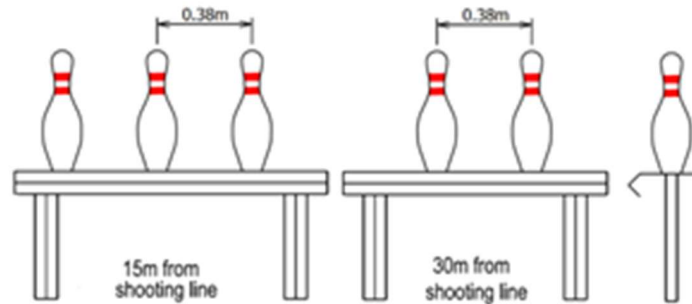

#### c. Event Rules

- i. A total of FIVE PINS will be placed as follows: Three pins to be placed 30 cm above ground level, 38 cm apart and at a distance of 15 meters from the front of the shooting line. A second row of two pins to be placed 40 cm above ground level, approximately 38 cm apart, at a distance of 30 meters from the shooting line.
- ii. Range layout may be changed by the Match Director, from the specifications above, to accommodate the available range and safety requirements, with adequate prior notice to competitors. Adequate prior notice will be at the invitation to the match.
- iii. A maximum of TEN ROUNDS may be pre-loaded before the start signal, under the direction of the Range Officer. See 4.4.g.
- iv. Re-loading of the firearm within the allotted time is allowed, provided that no more than ten rounds are loaded at any one time.
- v. The competitor will start in the standing erect behind the shooting line, roughly in the centre of the two tiers of PINS or where indicated.
- vi. On the start signal, the shooter may engage all pins from standing, kneeling, sitting or prone position.
- vii. If shooting from the standing, kneeling, or sitting position, the firearm will either be:
  - i. shouldered in the low ready position with the barrel or fore-end of the firearm touching the rail or indicating to the rail (if it is on the ground), with finger clearly outside of trigger guard; or
  - ii. placed on a bag / on the ground / on opened bipods. Should the rifle be placed for the start or between strings, whether it is rested on a bipod or a bag, the butt of the stock must rest on the ground or shooting mat (i.e. the rifle cannot be placed / balanced horizontally on a bag at any time). If the competitor is not using a bipod or bag, the rifle may be placed on the ground / shooting mat.
- viii. If shooting from the prone position, the firearm SHALL BE placed on a bag / on the ground / on opened bipods. Should the rifle be placed for the start or between strings, whether it is rested on a bipod or a bag, the butt of the stock must rest on the ground or shooting mat (i.e. the rifle cannot be placed / balanced horizontally on a bag at any time). If the competitor is not using a bipod or bag, the rifle may be placed on the ground / shooting mat.

- ix. Subject to safety considerations of Range layout etc, the starting and shooting positions as set out in Paragraphs iv, v and vi above may be changed by the Match Director, from the specifications above. Such changes will be set out clearly in the invitation to the match.
- x. If two or more shooting positions are available, it is suggested that competitors alternate between such positions in an effort to eliminate any unfair advantage one competitor may have over the other.
- xi. Any device not stipulated above that allows an unfair advantage and not in keeping with the general spirit of sportsmanship will be excluded from use in this event.
- xii. Junior Competitors Under 14 will be allowed to use a bipod, tripod or bean bag as rest while shooting. Their score will only be formally recognized against other Junior-Under 14, although at club level this may be waived to encourage junior shooters.

## A.11. Rimfire Rifle Self-Loading Event - Eight Pin

### a. Firearm Description.

- i. A "Rimfire Self-Loading Rifle" by definition shall mean a self-loading .22 Rimfire Rifle.
- ii. Optical sights, open sights and silencers are allowed.

### b. Table Layout (front view and side view)

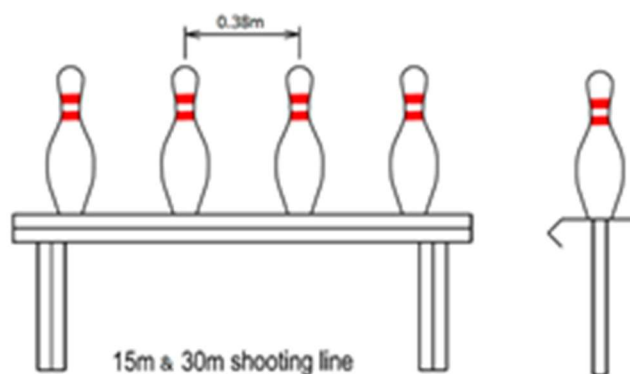

### c. Event Rules

- i. A total of EIGHT PINS will be placed as follows: four pins to be placed 40 cm above ground level, 38 cm apart and at a distance of 15 meters from the front of the shooting line; and a second row of four pins to be placed 40 cm above ground level, approximately 38 cm apart, at a distance of 30 meters from the shooting line
- ii. Range layout may be changed by the Match Director, from the specifications above, to accommodate the available range and safety requirements, with adequate prior notice to competitors. Adequate prior notice will be at the invitation to the match.
- iii. An unlimited number of rounds may be pre-loaded before the start signal, under the direction of the Range Officer.
- iv. Re-loading of the firearm within the allotted time is allowed.
  - i. The competitor will start in the standing erect behind the shooting line, roughly in the centre of the two tiers of PINS or where indicated.
  - ii. On the start signal, the shooter may engage all pins from standing, kneeling, sitting or prone position.
  - iii. If shooting from the standing, kneeling, or sitting position, the firearm will either be:
    - i. shouldered in the low ready position with the barrel or fore-end of the firearm touching the rail or indicating to the rail (if it is on the ground), with finger clearly outside of trigger guard; or
    - ii. placed on a bag / on the ground / on opened bipods. Should the rifle be placed for the start or between strings, whether it is rested on a bipod or a bag, the butt of the stock must rest on the ground or shooting mat (i.e. the rifle cannot be placed / balanced horizontally on a bag at any time). If the competitor is not using a bipod or bag, the rifle may be placed on the ground / shooting mat.
  - iv. If shooting from the prone position, the firearm SHALL BE placed on a bag / on the ground / on opened bipods. Should the rifle be placed for the start or between strings, whether it is rested on a bipod or a bag, the butt of the stock must rest on the ground or shooting mat (i.e. the rifle cannot be placed / balanced horizontally on a bag at any time). If the competitor is not using a bipod or bag, the rifle may be placed on the ground / shooting mat.
  - v. Subject to safety considerations of Range layout etc, the starting and shooting positions as set out in Paragraphs iv, v and vi above may be changed by the Match Director, from the specifications above. Such changes will be set out clearly in the invitation to the match.

- vi. If two or more shooting positions are available, it is suggested that competitors alternate between such positions in an effort to eliminate any unfair advantage one competitor may have over the other.
- vii. Any device not stipulated above that allows an unfair advantage and not in keeping with the general spirit of sportsmanship will be excluded from use in this event.
- viii. Junior Competitors Under 14 will be allowed to use a bipod, tripod or bean bag as rest while shooting. Their score will only be formally recognized against other Junior-Under 14, although at club level this may be waived to encourage junior shooters.

## Elective Shotgun Events:

### A.12. Shotgun Manual Event - Five Pins

#### a. Firearm Description.

- i. A "Shotgun Manual" by definition shall mean manually operated shotgun which is a pump action, break-neck, side-by-side or over & under shotgun etc. Or other manually operated shotgun that requires manual re-loading after being fired. This excludes any shotgun with a detachable magazine.
- ii. Optical sights, open sights and fibre optic inserts are allowed.

#### b. Table Layout (front view and side view)

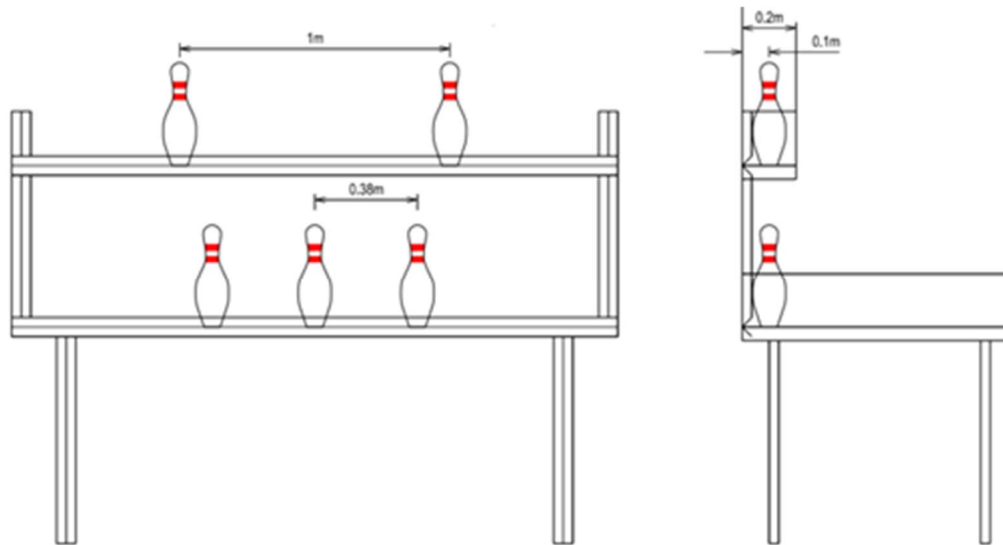

#### c. Event Rules

- i. A total of FIVE PINS to be placed on a double tier table, two pins on the top tier spaced apart by 1m and three pins on the bottom tier spaced apart by 38 cm, at a distance of 7.6 meters from the front of the shooting line.
- ii. A maximum of THREE shells may be loaded before the start signal, under the instruction of the Range Officer.
- iii. Starting position will be: Shotgun loaded with a maximum of THREE shells, safety engaged (where applicable), finger clearly outside of the trigger guard, and the barrel of the firearm touching the rail at the "Guns on the rail" command.
- iv. Manual re-loading of the shotgun within the allotted time is allowed, but only after the first shot has been fired.
- v. Additional shells may be kept on the shooting rail, in belt clips, *competition shotgun* shell holders, speed loader, in an ammo box, wooden blocks or in a stripper clip attached to the firearm, as long as safety is not compromised.
- vi. Any device not stipulated above that allows an unfair advantage and not in keeping with the general spirit of sportsmanship will be excluded from use in this Event.

## A.13. Shotgun Self-Loading Event - Five Pin

### a. Firearm Description.

- i. A "Shotgun Self-loading" by definition shall mean a self-loading shotgun. Shotguns with a detachable magazine are permitted. See Ammunition Classification, 6.4 for permitted shot sizes.
- ii. Optical sights, open sights and fibre optic inserts are allowed.
- iii. Muzzle brakes and other similar muzzle devices are allowed.

### b. Table Layout (front view and side view)

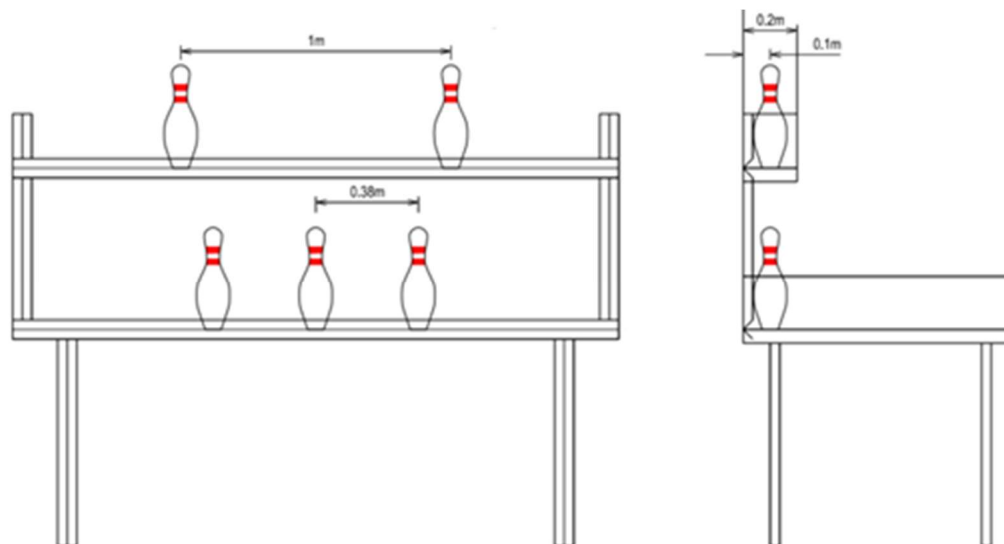

### c. Event Rules

- i. A maximum of THREE shells may be loaded before the start signal, under the instruction of the Range Officer. If loading from a magazine, the firearm, with magazine inserted, may only hold a total of three rounds at the start.
- ii. Starting position will be Shotgun loaded, safety engaged (where applicable), finger clearly outside of the trigger guard, and the barrel of the firearm touching the rail at the "Guns on the rail" command.
- iii. Manual re-loading of the shotgun within the allotted time is allowed, but only after the first shot has been fired.
- iv. Additional shells may be kept on the shooting rail, in belt clips, *competition shotgun* shell holders, speed loader, in an ammo box, additional magazine, wooden blocks or in a stripper clip attached to the firearm, as long as safety is not compromised. If a magazine-fed firearm is used, the magazine with which the shooting commences must be discarded and another magazine must be inserted in the firearm on reloading. Therefore, two magazines attached to each other, is not allowed
- v. Any device not stipulated above that allows an unfair advantage and not in keeping with the general spirit of sportsmanship will be excluded from use in this event

## A.14. Shotgun Open - Five Pins

### a. Firearm Description.

- i. An "Open Shotgun" by definition shall mean any shotgun, including shotguns to which with any safe and legal modifications have been made.
- ii. Optical sights, compensators, detachable magazines and speed-loaders are allowed.

### b. Table Layout (front view and side view)

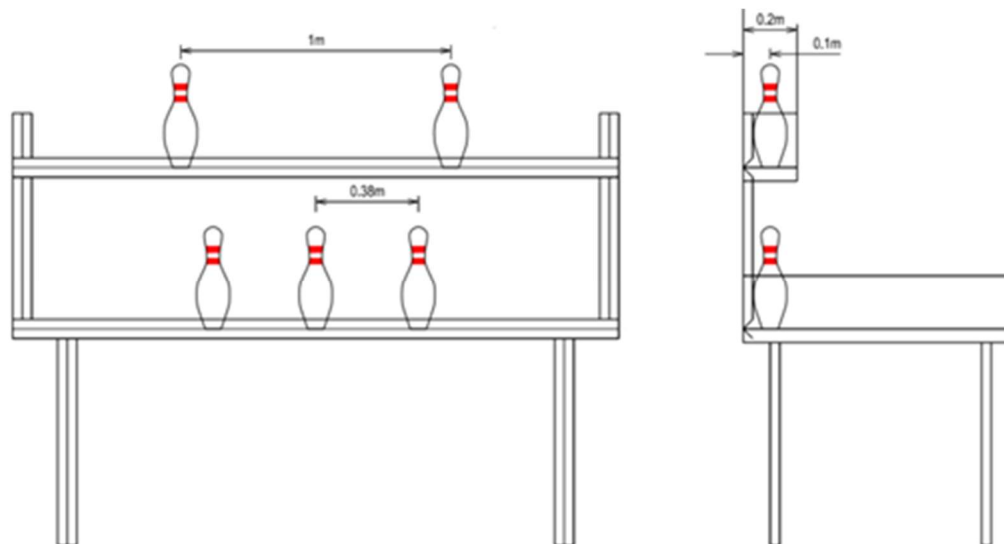

### c. Event Rules

- i. The shotgun may be loaded to the maximum before the start signal, under the instruction of the Range Officer.
- ii. Starting position will be Shotgun fully loaded to maximum, safety engaged (where applicable), finger clearly outside of the trigger guard, and the barrel of the firearm touching the rail at the "Guns on the rail" command.
- iii. Re-loading of the shotgun within the allotted time is allowed, but only after the first shot has been fired.

## Elective Centre Fire Rifle Events:

### A.15. Light Rifle Manual Event - Five Pins

#### a. Firearm Description.

- i. A "Light Rifle Manual" by definition shall mean a manually operated centrefire rifle. This includes lever-action, bolt-action and pump-action rifles, etc. The Light Rifle Manual is chambered in a Light rifle cartridge, see Ammunition Classification, 6.2 above.
- ii. A "Light Rifle Manual" by definition shall mean a manually operated centrefire Light Rifle. This includes lever-action, bolt-action and pump-action rifles, etc.
- iii. Open sights or optical sights will be allowed.

#### b. Table Layout (front view and side view)

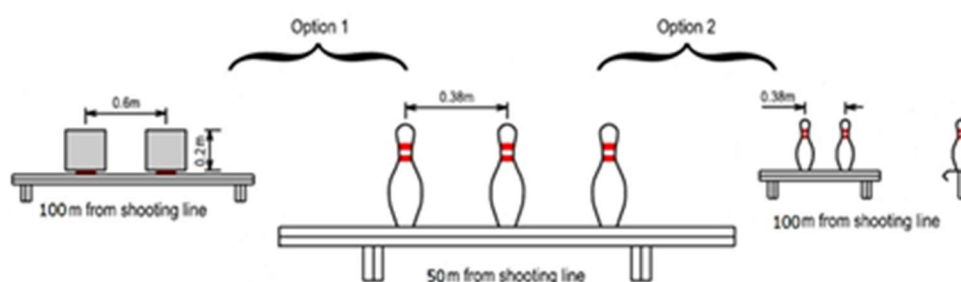

#### c. Event Rules

##### Layout:

- i. A maximum of FIVE ROUNDS may be pre-loaded before the start signal, under the direction of the Range Officer. Maximum rounds in firearm at any time is five rounds.
- ii. Re-loading of the firearm within the allotted time is allowed.
- iii. The rifle may be supported on **one only** of a magazine, a front bipod or a bag. Maximum height for a bipod is 300mm and it may be adjustable and swiveled. The maximum dimension for a bag is 300 x 300 x 300mm. If it is grooved (i.e. an X-bag), the groove must be perpendicular to the target direction. The shooter may not make any crease or line on the bag to indicate where the rifle is to be rested. The rifle may be rested at one point only (a bag or X-bag turned sideways will be regarded as one point). In the case of a bag, the rifle may be rested at any point between (and including) the magazine (provided it is in front of the trigger guard) to the front of the stock. It is permissible that the shooter's forward hand may be rested on the bag while holding the front end of the stock. Should the magazine be rested on a bag, the combined height of the magazine and the bag may not be more than 300mm. Note that if the magazine is rested on a bag, no form of indent or crease may be utilized to stabilize it, including the groove of a sideways X-bag.
- iv. In addition to the above, a sling is allowed to stabilize the rifle. Tripods are not allowed.
- v. Before commencing fire and under direction of the Range Officer, a competitor will be given the opportunity to set the bipod height or adjust the bag position (if either are used) and adjust the scope or iron sights while aiming at the targets. The maximum time to set up will be 60 seconds. If a bipod is used, its leg/s must be deployed before loading the rifle.
- vi. No handling of firearm between strings.

### **Start and Starting Position:**

- i. The competitor will start standing erect in the designated area.
- ii. The rifle must be placed on the bag, on the ground, on opened bipod. The butt of the stock must rest on the ground or shooting mat (i.e. the rifle cannot be placed / balanced horizontally on a bag at any time). If the competitor is not using a bipod or bag, the rifle may be placed on the ground / shooting mat.
- iii. On the start signal, the shooter may engage all pins from standing, kneeling, sitting or prone position.
- iv. While shooting, the butt of the rifle must be supported against the shooter's shoulder. No artificial rear support of any nature (i.e. bag) may be used.
- v. Any device not stipulated above that allows for an unfair advantage, and not in keeping with the general spirit of sportsmanship, will be excluded from use in this event.
- vi. If two or more range set-ups are possible, it is suggested that competitors swap positions to eliminate any unfair advantage one competitor may have over the other.
- vii. It is recommended that pins be used as targets throughout, even at the further distance, in keeping with our sport of PIN shooting and to avoid the use of plates, if possible.
- viii. The Starting and Shooting positions are subject to safety considerations due to the range layout etc. The starting and shooting positions may be changed by the Match Director, from the specifications above. Such changes will be set out clearly in the invitation to the match.

## A.16. Light Rifle Self-Loading Event - Eight Pins

### a. Firearm Description.

- i. A "Light Rifle Self-loading" by definition shall mean a self-loading centrefire light rifle that is chambered in a Light rifle cartridge, see Ammunition Classification, 6.2 above.
- ii. Open sights, optical sights, silencers, muzzle brakes and compensators are allowed.

### b. Table Layout (front view and side view)

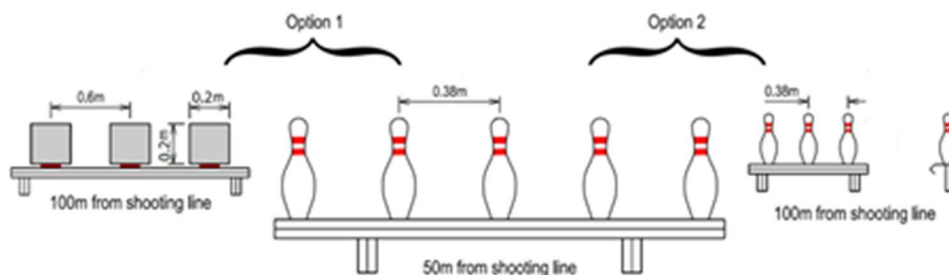

### c. Event Rules

- ix. A total of EIGHT PINS will be placed as follows: five full-sized pins to be placed 20 cm above ground level, approximately 38 cm apart and at a distance of 50 meters from the front of the shooting line; and a second row of three full-sized pins to be placed 20 cm above ground level, approximately 38 cm apart, at a distance of 100 meters from the shooting line.
- x. The range layout may be changed by the Match Director from the specifications above to accommodate the available range and safety parameters, with adequate prior notice to competitors. Adequate prior notice will be at the invitation to the match.

#### Rifle Setup:

- i. An unlimited number of rounds may be pre-loaded before the start signal, under the direction of the Range Officer.
- ii. Re-loading of the firearm within the allotted time is allowed. No limit on ammunition.
- iii. The rifle may be supported on **one only** of a magazine, a front bipod or a bag. Maximum height for a bipod is 300mm and it may be adjustable and swiveled. The maximum dimension for a bag is 300 x 300 x 300mm. If it is grooved (i.e. an X-bag), the groove must be perpendicular to the target direction. The shooter may not make any crease or line on the bag to indicate where the rifle is to be rested. The rifle may be rested at one point only (a bag or X-bag turned sideways will be regarded as one point). In the case of a bag, the rifle may be rested at any point between (and including) the magazine (provided it is in front of the trigger guard) to the front of the stock. It is permissible that the shooter's forward hand may be rested on the bag while holding the front end of the stock. Should the magazine be rested on a bag, the combined height of the magazine and the bag may not be more than 300mm. Note that if the magazine is rested on a bag, no form of indent or crease may be utilized to stabilize it, including the groove of a sideways X-bag.
- iv. In addition to the above, a sling is allowed to stabilize the rifle. Tripods are not allowed.
- v. Before commencing fire and under direction of the Range Officer, a competitor will be given the opportunity to set the bipod height or adjust the bag position (if either are used) and adjust the scope or iron sights while aiming at the targets. The maximum time to set up will be 60 seconds. If a bipod is used, its leg/s must be deployed before loading the rifle.
- vi. No handling of firearm between strings.

### **Start and Starting Position:**

- ix. The competitor will start standing erect in the designated area.
- x. The rifle must be placed on the bag, on the ground, on opened bipod. The butt of the stock must rest on the ground or shooting mat (i.e. the rifle cannot be placed / balanced horizontally on a bag at any time). If the competitor is not using a bipod or bag, the rifle may be placed on the ground / shooting mat.
- xi. On the start signal, the shooter may engage all pins from standing, kneeling, sitting or prone position.
- xii. While shooting, the butt of the rifle must be supported against the shooter's shoulder. No artificial rear support of any nature (i.e. bag) may be used.
- xiii. Any device not stipulated above that allows for an unfair advantage, and not in keeping with the general spirit of sportsmanship, will be excluded from use in this event.
- xiv. If two or more range set-ups are possible, it is suggested that competitors swap positions to eliminate any unfair advantage one competitor may have over the other.
- xv. It is recommended that pins be used as targets throughout, even at the further distance, in keeping with our sport of PIN shooting and to avoid the use of plates, if possible.
- xvi. The Starting and Shooting positions are subject to safety considerations due to the range layout etc. The starting and shooting positions may be changed by the Match Director, from the specifications above. Such changes will be set out clearly in the invitation to the match.

## A.17. Rifle Manual Event - Five Pins

### a. Firearm Description.

- i. A "Rifle Manual" by definition shall mean a manually operated centrefire rifle. This includes lever-action, bolt-action and pump-action rifles, etc. The Rifle Manual is chambered in a Rifle cartridge, see Ammunition Classification, 6.3 above.
- ii. Open sights or optical sights, silencers and muzzle brakes will be allowed.

### b. Table Layout (front view and side view)

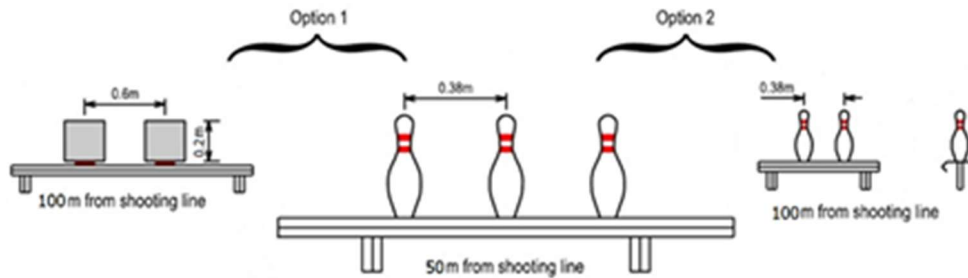

### c. Event Rules

#### Layout:

- i. A maximum of FIVE ROUNDS may be pre-loaded before the start signal, under the direction of the Range Officer. Maximum rounds in firearm at any time is five rounds.
- ii. Re-loading of the firearm within the allotted time is allowed.
- iii. The rifle may be supported on **one only** of a magazine, a front bipod or a bag. Maximum height for a bipod is 300mm and it may be adjustable and swiveled. The maximum dimension for a bag is 300 x 300 x 300mm. If it is grooved (i.e. an X-bag), the groove must be perpendicular to the target direction. The shooter may not make any crease or line on the bag to indicate where the rifle is to be rested. The rifle may be rested at one point only (a bag or X-bag turned sideways will be regarded as one point). In the case of a bag, the rifle may be rested at any point between (and including) the magazine (provided it is in front of the trigger guard) to the front of the stock. It is permissible that the shooter's forward hand may be rested on the bag while holding the front end of the stock. Should the magazine be rested on a bag, the combined height of the magazine and the bag may not be more than 300mm. Note that if the magazine is rested on a bag, no form of indent or crease may be utilized to stabilize it, including the groove of a sideways X-bag.
- iv. In addition to the above, a sling is allowed to stabilize the rifle. Tripods are not allowed.
- v. Before commencing fire and under direction of the Range Officer, a competitor will be given the opportunity to set the bipod height or adjust the bag position (if either are used) and adjust the scope or iron sights while aiming at the targets. The maximum time to set up will be 60 seconds. If a bipod is used, its leg/s must be deployed before loading the rifle.
- vi. No handling of firearm between strings.

#### Start and Starting Position:

- i. The competitor will start standing erect in the designated area.
- ii. The rifle must be placed on the bag, on the ground, on opened bipod. The butt of the stock must rest on the ground or shooting mat (i.e. the rifle cannot be placed / balanced horizontally on a bag at any time). If the competitor is not using a bipod or bag, the rifle may be placed on the ground / shooting mat.
- iii. On the start signal, the shooter may engage all pins from standing, kneeling, sitting or prone position.

- iv. While shooting, the butt of the rifle must be supported against the shooter's shoulder. No artificial rear support of any nature (i.e. bag) may be used.
- v. Any device not stipulated above that allows for an unfair advantage, and not in keeping with the general spirit of sportsmanship, will be excluded from use in this event.
- vi. If two or more range set-ups are possible, it is suggested that competitors swap positions to eliminate any unfair advantage one competitor may have over the other.
- vii. It is recommended that pins be used as targets throughout, even at the further distance, in keeping with our sport of PIN shooting and to avoid the use of plates, if possible.
- viii. The Starting and Shooting positions are subject to safety considerations due to the range layout etc. The starting and shooting positions may be changed by the Match Director, from the specifications above. Such changes will be set out clearly in the invitation to the match.

## A.18. Rifle Self-loading Event - Eight Pins

### a. Firearm Description.

- i. A "Rifle Self-loading" by definition shall mean a self-loading centrefire rifle that is chambered in a Rifle cartridge, see Ammunition Classification, 6.3 above.
- ii. Open sights, optical sights, silencers, muzzle brakes and compensators are allowed.

### b. Table Layout (front view and side view)

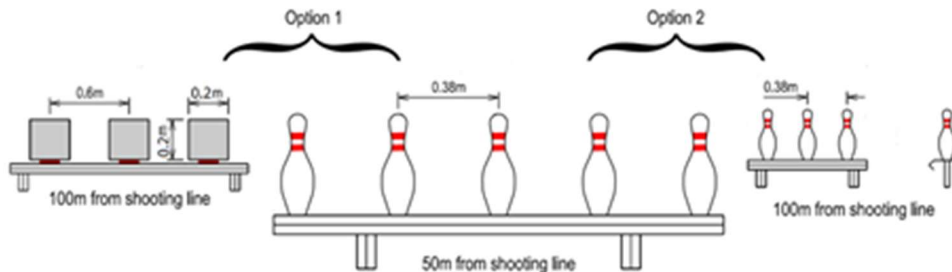

### c. Event Rules

- i. A total of EIGHT PINS will be placed as follows: five full-sized pins to be placed 20 cm above ground level, approximately 38 cm apart and at a distance of 50 meters from the front of the shooting line; and a second row of three full-sized pins to be placed 20 cm above ground level, approximately 38 cm apart, at a distance of 100 meters from the shooting line.
- ii. The range layout may be changed by the Match Director from the specifications above to accommodate the available range and safety parameters, with adequate prior notice to competitors. Adequate prior notice will be at the invitation to the match.

#### Rifle Setup:

- i. An unlimited number of rounds may be pre-loaded before the start signal, under the direction of the Range Officer.
- ii. Re-loading of the firearm within the allotted time is allowed. No maximum ammunition specified.
- iii. The rifle may be supported on **one only** of a magazine, a front bipod or a bag. Maximum height for a bipod is 300mm and it may be adjustable and swiveled. The maximum dimension for a bag is 300 x 300 x 300mm. If it is grooved (i.e. an X-bag), the groove must be perpendicular to the target direction. The shooter may not make any crease or line on the bag to indicate where the rifle is to be rested. The rifle may be rested at one point only (a bag or X-bag turned sideways will be regarded as one point). In the case of a bag, the rifle may be rested at any point between (and including) the magazine (provided it is in front of the trigger guard) to the front of the stock. It is permissible that the shooter's forward hand may be rested on the bag while holding the front end of the stock. Should the magazine be rested on a bag, the combined height of the magazine and the bag may not be more than 300mm. Note that if the magazine is rested on a bag, no form of indent or crease may be utilized to stabilize it, including the groove of a sideways X-bag.
- iv. In addition to the above, a sling is allowed to stabilize the rifle. Tripods are not allowed.
- v. Before commencing fire and under direction of the Range Officer, a competitor will be given the opportunity to set the bipod height or adjust the bag position (if either are used) and adjust the scope or iron sights while aiming at the targets. The maximum time to set up will be 60 seconds. If a bipod is used, its leg/s must be deployed before loading the rifle.
- vi. No handling of firearm between strings.

#### Start and Starting Position:

- i. The competitor will start standing erect in the designated area.

- ii. The rifle must be placed on the bag, on the ground, on opened bipod. The butt of the stock must rest on the ground or shooting mat (i.e. the rifle cannot be placed / balanced horizontally on a bag at any time). If the competitor is not using a bipod or bag, the rifle may be placed on the ground / shooting mat.
- iii. On the start signal, the shooter may engage all pins from standing, kneeling, sitting or prone position.
- iv. While shooting, the butt of the rifle must be supported against the shooter's shoulder. No artificial rear support of any nature (i.e. bag) may be used.
- v. Any device not stipulated above that allows for an unfair advantage, and not in keeping with the general spirit of sportsmanship will be excluded from use in this event.
- vi. If two or more range set-ups are possible, it is suggested that competitors swap positions in an effort to eliminate any unfair advantage one competitor may have over the other.
- vii. It is recommended that pins be used as targets throughout, even at the further distance, in keeping with our sport of PIN shooting and to avoid the use of plates, if possible.
- viii. The Starting and Shooting positions are subject to safety considerations due to the range layout etc. The starting and shooting positions may be changed by the Match Director, from the specifications above. Such changes will be set out clearly in the invitation to the match.

## A.19. Carbine Manual Event - Five Pins

### a. Firearm Description.

- i. A "Carbine Manual" by definition shall mean a manually operated carbine that is chambered in a handgun calibre cartridge, see Ammunition Classification, 6.1 above. Action may be bolt-action, lever-action, pump-action, cylinder or any other manually actuated type.
- ii. Any centre-fired rifle (bolt-action, lever-action, pump-action) may be used.
- iii. Optical sights or open sights will be allowed.

### b. Table Layout (front view and side view)

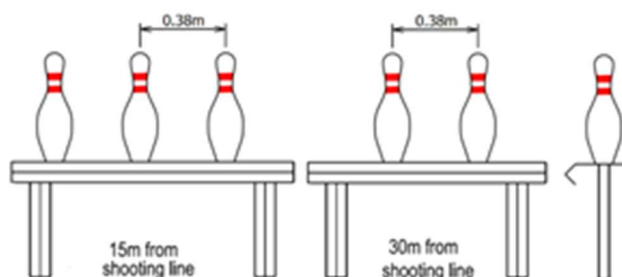

### c. Event Rules

- i. A total of FIVE PINS will be placed as follows: Three pins to be placed 30 cm above ground level, 38 cm apart and at a distance of 15 meters from the front of the shooting line. A second row of two pins to be placed 40 cm above ground level, approximately 38 cm apart, at a distance of 30 meters from the shooting line.
- ii. The range layout may be changed by the Match Director, from the specifications above, to accommodate the available range and safety requirements, with adequate prior notice to competitors. Adequate prior notice will be at the invitation to the match.
- iii. A maximum of **TEN ROUNDS** may be pre-loaded before the start signal, under the direction of the Range Officer. See 4.4.g.
- iv. Re-loading of the firearm within the allotted time is allowed, as long as no more than ten rounds are loaded at any one time.
- i. The competitor will start in the standing erect behind the shooting line, roughly in the centre of the two tiers of PINS or where indicated.
- ii. On the start signal, the shooter may engage all pins from standing, kneeling, sitting or prone position.
- iii. If shooting from the standing, kneeling, or sitting position, the firearm will either be:
  - i. shouldered in the low ready position with the barrel or fore-end of the firearm touching the rail or indicating to the rail (if it is on the ground), with finger clearly outside of trigger guard; or
  - ii. placed on a bag / on the ground / on opened bipods. Should the rifle be placed for the start or between strings, whether it is rested on a bipod or a bag, the butt of the stock must rest on the ground or shooting mat (i.e. the rifle cannot be placed / balanced horizontally on a bag at any time). If the competitor is not using a bipod or bag, the rifle may be placed on the ground / shooting mat.
- iv. If shooting from the prone position, the firearm **SHALL BE** placed on a bag / on the ground / on opened bipods. Should the rifle be placed for the start or between strings, whether it is rested on a bipod or a bag, the butt of the stock must rest on the ground or shooting mat (i.e. the rifle cannot

be placed / balanced horizontally on a bag at any time). If the competitor is not using a bipod or bag, the rifle may be placed on the ground / shooting mat.

- v. Subject to safety considerations of Range layout etc, the starting and shooting positions as set out in Paragraphs iv, v and vi above may be changed by the Match Director, from the specifications above. Such changes will be set out clearly in the invitation to the match.
- vi. If two or more shooting positions are available, it is suggested that competitors alternate between such positions in an effort to eliminate any unfair advantage one competitor may have over the other.
- vii. Any device not stipulated above that allows an unfair advantage and not in keeping with the general spirit of sportsmanship will be excluded from use in this event.
- viii. Junior Competitors Under 14 years will be allowed to use a bipod, tripod or bean bag as rest while shooting. Their score will only be formally recognized against other Junior Under-14's, although at club level this may be waived to encourage junior shooters.

## A.20. Carbine Self-loading Event - Eight Pins

### a. Firearm Description.

- i. A "Carbine Self-loading" by definition shall mean a self-loading carbine that is chambered in a handgun calibre cartridge, see Ammunition Classification, 61 above. This includes normal carbines, as well as carbine-conversion kits attached to pistols. As .30 Carbine calibre is used in both revolvers and pistols, it will be allowed in this category.
- ii. Optical sights or open sights are allowed.

### b. Table Layout (front view and side view)

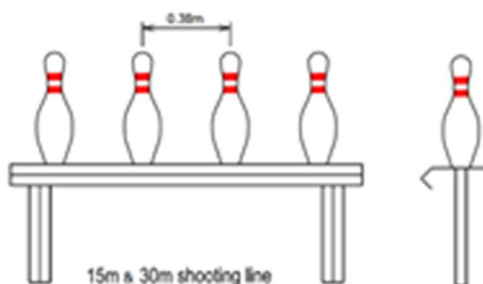

### c. Event Rules

- i. A total of EIGHT PINS will be placed as follows: four pins to be placed 40 cm above ground level, 38 cm apart and at a distance of 15 meters from the front of the shooting line; and a second row of four pins to be placed 40 cm above ground level, approximately 38 cm apart, at a distance of 30 meters from the shooting line.
- ii. The range layout may be changed by the Match Director, from the specifications above, to accommodate the available range and safety requirements, with adequate prior notice to competitors. Adequate prior notice will be at the invitation to the match.
- iii. An UNLIMITED number of rounds may be pre-loaded before the start signal, under the direction of the Range Officer.
- iv. Re-loading of the firearm within the allotted time is allowed.
- v. The competitor will start in the standing erect behind the shooting line, roughly in the centre of the two tiers of PINS or where indicated.
- vi. On the start signal, the shooter may engage all pins from standing, kneeling, sitting or prone position.
- vii. If shooting from the standing, kneeling, or sitting position, the firearm will either be:
  - i. shouldered in the low ready position with the barrel or fore-end of the firearm touching the rail or indicating to the rail (if it is on the ground), with finger clearly outside of trigger guard; or
  - ii. placed on a bag / on the ground / on opened bipods. Should the rifle be placed for the start or between strings, whether it is rested on a bipod or a bag, the butt of the stock must rest on the ground or shooting mat (i.e. the rifle cannot be placed / balanced horizontally on a bag at any time). If the competitor is not using a bipod or bag, the rifle may be placed on the ground / shooting mat.
- viii. If shooting from the prone position, the firearm SHALL BE placed on a bag / on the ground / on opened bipods. Should the rifle be placed for the start or between strings, whether it is rested on a bipod or a bag, the butt of the stock must rest on the ground or shooting mat (i.e. the rifle cannot be placed / balanced horizontally on a bag at any time). If the competitor is not using a bipod or bag, the rifle may be placed on the ground / shooting mat.

- ix. Subject to safety considerations of Range layout etc, the starting and shooting positions as set out in Paragraphs iv, v and vi above may be changed by the Match Director, from the specifications above. Such changes will be set out clearly in the invitation to the match.
- x. If two or more shooting positions are available, it is suggested that competitors alternate between such positions in an effort to eliminate any unfair advantage one competitor may have over the other.
- xi. Any device not stipulated above that allows an unfair advantage and not in keeping with the general spirit of sportsmanship will be excluded from use in this event.
- xii. Junior Competitors Under 14 years will be allowed to use a bipod, tripod or bean bag as rest while shooting. Their score will only be formally recognized against other Junior Under-14's, although at club level this may be waived to encourage junior shooters.

## Appendix B. Elimination Match

### **Eliminations: Top Sixteen Shooters Elimination Contest**

The top sixteen finalists in a discipline will be considered in an elimination shoot-out contest.

Contestants will be paired off according to their positions, e.g. first versus sixteenth, second versus fifteenth, third versus fourteenth, etc. If any contestant fails to appear or is unavailable at the elimination contest, the next highest placed contestant will automatically qualify to participate in this elimination contest, until all sixteen positions are filled.

Shoot-out will continue until an ultimate winner is declared. See Elimination Event Score Sheet below.

# Elimination Event Score Sheet

Event: \_\_\_\_\_

## Heat One:

<b>Shootout 1</b>	<b>Shootout 2</b>
Position 1:	Position 2:
Position 16:	Position 15:
<b>Shootout 3</b>	<b>Shootout 4</b>
Position 3:	Position 4:
Position 14:	Position 13:
<b>Shootout 5</b>	<b>Shootout 6</b>
Position 5:	Position 6:
Position 12:	Position 11:
<b>Shootout 7</b>	<b>Shootout 8</b>
Position 7:	Position 8:
Position 10:	Position 9:

## Heat Two:

<b>Shootout 9</b>	<b>Shootout 10</b>
Winner of 1:	Winner of 2:
Winner of 8:	Winner of 7:
<b>Shootout 11</b>	<b>Shootout 12</b>
Winner of 3:	Winner of 4:
Winner of 6:	Winner of 5:

## Final Heat:

Winner of 9:	Winner of 10:
Time:	Time:
Winner of 11:	Winner of 12:
Time:	Time:

## Appendix C. Quick Reference Summary of Range Commands

The following range commands shall be used at all PIN shooting matches.

Ref. to 4.5, pp. 12-15

- A. **“THE RANGE IS CLOSED”**
- B. **“SHOOTERS TO THE LINE”**
- C. **“YOU MAY UNBAG YOUR FIREARMS AND SHOW CLEAR”**
- D. **“LOAD AND MAKE READY”**
- E. **“SHOOTERS ARE YOU READY?”**
- F. **“TIMERS ARE YOU READY?”**
- G. **“GUNS ON THE RAIL”**
- H. **START SIGNAL**
- I. **STOP SIGNAL - “CEASE FIRE”** in an emergency
- J. **“CEASE FIRE, UNLOAD AND SHOW CLEAR”**
- K. **“IF CLEAR, TAKE YOUR AMMUNITION AND MAGAZINES, AND STAND BACK”** (if competitor has to shoot another string to be shot at same table)  

**OR**
- L. **“IF CLEAR, MOVE ACROSS”** (if competitor has to shoot another string at the next table)  

**OR**
- M. **“IF GUN CLEAR, HAMMER DOWN, BAG: CONFIRM”** (if the competitor has finished the event)
- N. **“RANGE IS CLEAR. PIN SETTERS MAY GO FORWARD”**

## Appendix D. Quick Reference Summary Text of Selected Pin Shooting Events

### **LEGACY EVENTS:**

#### **A1, P. 28: PIN GUN:**

FIVE PINS, pistol or revolver may be used. A maximum of EIGHT ROUNDS may be loaded before the start signal. No more than eight rounds are in the firearm at any one time. Full moon clips, half-moon clips or speed loaders may be used.

#### **A2. P. 29: STOCK GUN (forced reload):**

- i. EIGHT PINS, maximum of EIGHT ROUNDS may be loaded in the firearm before the start signal, or at any time during the event. Any 2 pistols, 2 revolvers or one pistol and one revolver may be used; both loaded with a maximum of EIGHT ROUNDS. Full moon clips or half-moon clips or speed loaders may be used.

#### **A3. P. 30: 9 PIN TIP-OVER:**

NINE PINS, pistols only may be used. No restriction on loading capacity of the magazine(s). Extended magazines are allowed. Weights and other performance-enhancing attachments are allowed. Either ONE of the following: a compensator OR a slide-mounted optical sight is allowed, but not both.

#### **A4. P. 31: PIN REVOLVER:**

FIVE PINS, any centre-fire revolver (single or double action) may be used. Eight-shot revolvers may be used, fully loaded before the start signal, re-loading up to 8 rounds allowed, speed loaders, half-moon clips or full moon clips are allowed. A second revolver is not allowed.

#### **A5. P. 32: STOCK REVOLVER (forced reload):**

EIGHT PINS, maximum of SIX ROUNDS may be loaded before the start signal, a maximum of SIX ROUNDS may be re-loaded, In the event that the shooter manages to clear the table with 6 shots, the shooter has to reload and fire a shot over the table in order to stop the time, NO speed loaders, NO half-moon clips and NO full moon clips may be used. A second revolver is not allowed.

## **ELECTIVE RIFLE EVENTS:**

### **A10, P. 38: RIMFIRE RIFLE MANUAL:**

5 PINS TOTAL, 3 Pins at 15m and 2 Pins 30m, maximum of 10 ROUNDS may be loaded before the start signal, no more than 10 rounds in the gun at any time.

Shooter starts in the Standing position. No resting of the rifle on any support. Rifle can be on the ground or held by the shooter at start.

### **A11, P. 40: RIMFIRE RIFLE SELF-LOADING:**

8 PINS TOTAL, 4 Pins at 15m and 4 Pins 30m, no limit on number of rounds loaded. Shooter starts in the Standing position. No resting of the rifle on any support. Rifle can be on the ground or held by the shooter at start.

### **A15 & 17, P. 44 &48: LIGHT RIFLE & RIFLE MANUAL:**

5 PINS TOTAL, 3 Pins at 50m and 2 Pins 100m, maximum of 5 ROUNDS may be loaded before the start signal, no more than 5 rounds in the gun at any time.

Bipods with maximum length of 300mm allowed and magazine resting allowed, but not both.

Shooting bags are allowed. If a magazine is used as a rest, then a bag can be used to raise the rifle as long as the magazine is the only point of contact. Rifle will be on the ground the shooter stand at start.

Tripods not allowed.

### **A16 & 18, P. 46 & 50: LIGHT RIFLE & RIFLE SELF-LOADING:**

8 PINS TOTAL, 5 Pins at 50m and 3 Pins 100m, no limit on number of rounds loaded. Bipods with maximum length of 300mm allowed and magazine resting allowed, but not both. Shooting bags are allowed. If a magazine is used as a rest, then a bag can be used to raise the rifle as long as the magazine is the only point of contact. Rifle will be on the ground shooter will stand at start. Tripods not allowed.

### **A19, P. 52: CARBINE MANUAL:**

5 PINS TOTAL, 3 Pins at 15m and 2 Pins at 30m, maximum of 10 ROUNDS may be loaded before the start signal, no more than 10 rounds in the gun at any time. Rifle can be on the ground or held by the shooter at start.

### **A20, P. 54: CARBINE SELF-LOADING:**

8 PINS TOTAL, 4 Pins at 15m and 4 Pins at 30m, no limit on number of rounds loaded. Rifle can be on the ground or held by the shooter at start.

## Appendix E. SAPSF Member's Code of Conduct

1. This rule book will be considered as being read.
2. Obey and support all Range Officer's commands without question. The Range Officer has complete authority.
3. During a PIN shoot, the PIN ranges are deemed private property, open only to members and their invited guests.
4. Guests must accompany at all times members. Members are responsible for the safe conduct of their guests at all times while on the Club's designated ranges.
5. Members must ensure that guests are familiarized with the safety rules relative to the planned activities.
6. Eye and ear protection is a compulsory requirement by all shooters and spectators at all times while shooting is in progress.
7. Every Club member will be subjected to a safety audit whenever necessary, in which any bad habits that may have developed will be pointed out for correction by the Range Officer's Committee.
8. Courteous behaviour to other members and guests is expected.
9. Continuous argumentative behaviour and/or bad sportsmanship could result in disciplinary actions against a member, and an offending shooter or guest can be asked to leave.
10. All accidents and / or incidents must be reported in writing to the Range Master.
11. South African law requires you to be in control of your firearms at all times. In addition, you must have your licenses to possess a firearm, at all times when shooting, carrying or conveying firearms and ammunition.
12. Membership of SAPSF is for a full calendar year and will start on the first day of January and end on the last day of December of the same year.
13. Membership fees are due on the first day of January of each calendar year and must be paid by the latest on the last day of March of that calendar year.
14. The Financial Year of SAPSF will start on the first day of March each year and end on the last day of February of the following year.
15. Red clothing worn outwardly is reserved for Range Officers only as a means of easy identification.
16. Appropriate dress and clothing must be worn. All paramilitary dress, camouflage clothing, clothing supporting a particular political affiliation, clothing that may be deemed offensive or

inciteful is strongly discouraged. The match officials have the right to ask the offending person to remove or cover the item of clothing.

17. The range being a public place, no smoking is allowed on the firing line or elsewhere where it disturbs fellow shooters, competitors or guests.
18. Alcohol may only be consumed by members or guests in designated area, i.e. clubhouse. Those members and guests consuming alcohol are not permitted on the range.
19. Violation of any safety rule and non-compliance to the Code of Conduct or SAPSF Constitution may cause the Executive Committee to take disciplinary action, which may include revoking of membership without refund of fees or recourse to any claim.
20. This Code of Conduct is subject to change at the discretion of the SAPSF Executive Committee. All members, invited guests and visitors are obliged to comply therewith.
21. This Code of Conduct is in keeping with and subject to the Constitution of the South African Pin Shooting Federation

## Appendix F. Construction Plan for a Double-Tier Table

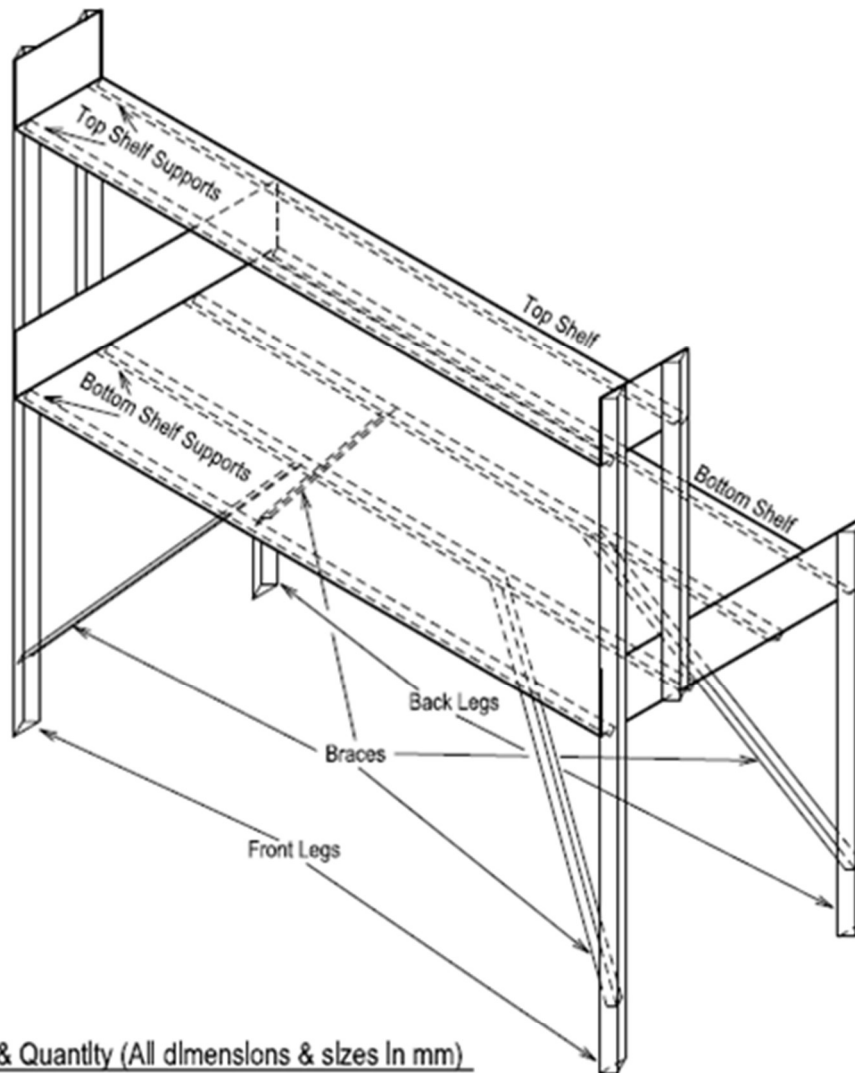

### Material List & Quantity (All dimensions & sizes in mm)

1. One (1) 4 x 1200 x 2400 Metal Sheet
  - a. Cut 1 strip of 300 x 2400 and bend end 200mm 90° for top shelf.
  - b. 90° Bend remaining 900 x 2400 also on 200mm for bottom shelf.
2. Two (2) 1800 x 50 x 5 Angle iron for front legs.
3. Two (2) 1000 x 50 x 5 Angle Iron for back legs.
4. Two (2) 800 x 30 x 3 Angle Iron for Top shelf back legs.
5. Six (6) 2000 x 30 x 3 Angle Iron for shelf support.
6. Four (4) 1000 x 30 x 3 Angle Iron for braces.
7. Two (2) 2000 x 70 x 5 Flat bar for top and bottom shelf bullet deflectors. Deflectors are welded to the front angle iron shelf support and clear top of shelf with  $\pm 5$ mm to avoid forward roll off of pins. Weld at 45° to deflect bullets downwards.

## Appendix G. General Provisions

1. This Rule Book is revised or amended at a Rule Book Conference held every four years, or as required. The SAPSF Executive Committee prepares the draft amended Rule Book and presents it to the SAPSF Council of Provinces at the conference for further amendments and / or approval.
2. Revisions of the Rule Book may only come into effect three months after the revision, in order for all RO's and members to become familiar with changes, except in the case of urgent safety related changes or changes necessitated by changes in legislation. When possible, revisions to the Rule Book should come into effect at the start of the year.
3. The SAPSF Executive Committee can alter, amend, or add any annexure to this Rule Book without mandate for issues of safety, changed legislation or other urgent issues. Ratification by the Council of changes so made must be obtained within a period of three months.
4. Members are required to become members of SAGA or any other similar body for insurance purposes.

## Appendix H. Occupational Health and Safety

To be compliant with OHS, the following forms are to be completed by the RM or RO before, during and after the match.

### **Occupational Health and Safety (OHS) compliance**

The OHS Act, 85 of 1993, applies to SAPSF activities to the extent that organizers, range operators and self-employed persons have a duty to ensure, as far as is reasonably practicable, that competitors, officials, volunteers, contractors and spectators are not exposed to hazards arising from match activities (OHS Act Sections 8 & 9). Where employee-specific provisions are triggered, clubs must comply; where there are no employees, organizers must still meet the Section 9 duty and relevant regulations to manage risks (e.g., PPE, first aid, emergency response, incident reporting).

## Range Officer Check List

<b>Range Officer</b>	<b>Name</b>	<b>Surname</b>	<b>Date</b>
----------------------	-------------	----------------	-------------

Item Number	Item	Checked
1	Clubhouse area clean	
2	Inspect the range; Backstop, Range surface (Scan the area)	
3	Ensure red flags are posted	
4	Inspection of range equipment	
5	Ensure warning boards are put in place	
6	Ensure First Aid Kit is on the range	
7	Ensure the ranges are set up	
8	Ensure that a nominated hospital driver has been notified	
9	Pre – shoot briefing done	
10	Ensure that all persons are wearing eye and ear protection	
11	Inspection of shooters equipment	
12	Ensure range is left clean	
13	Record any incidents on the range	
14	Incident register signed off	

**Comments**

<b>Signature</b>
------------------

### SAPSF Incident Register

<b>INCIDENT REPORT</b>		<b>DATE:</b>		
<b>COMPLAINT</b>	<b>ACCIDENT</b>	<b>SAFETY INFRINGEMENT</b>	<b>DAMAGE</b>	<b>OTHER</b>
<b>INCIDENT DETAILS :</b>				
<b>Reported By</b>	<b>Name</b>		<b>MTSC Number</b>	
	<b>Surname</b>		<b>Signature</b>	

<b>INCIDENT REPORT</b>		<b>DATE:</b>		
<b>COMPLAINT</b>	<b>ACCIDENT</b>	<b>SAFETY INFRINGEMENT</b>	<b>DAMAGE</b>	<b>OTHER</b>
<b>INCIDENT DETAILS :</b>				
<b>Reported By</b>	<b>Name</b>		<b>MTSC Number</b>	
	<b>Surname</b>		<b>Signature</b>	



## Appendix I. Acknowledgements and Credits

The South African Pin Shooting Federation expresses its appreciation to its members who contributed to its successive Rule Books during the period 2012 to 2022. They are:

**Kevin Addison**  
Council: PSAWP

**Tony Baia**  
SAPSF Exco; SAPSF Chief RO

**Tinus Botha**  
Council: LPSA, Chairperson LPSA

**Mahmood Cassim**  
SAPSF Exco, Secretary

**William Colombo**  
SAPSF Past President  
Council: PSAWP; Chairperson PSAWP

**Innocenzo Di-Sante**  
SAPSF Exco, Treasurer

**Mahmood Doola**  
Council: GPSA

**Johan Ehlers**  
Council: LPSA

**Alwin Fleischmann**  
Council: LPSA

**Stefano Ghigini**  
Council: GPSA

**Jorge Goncalves**  
SAPSF Vice President

**Stephen Marais**  
SAPSF Exco, Secretary; SAPSF Chief RO

**Tinnie Nieuwoudt**  
Council: LPSA

**Franco Rossouw**  
Council: LPSA

**Christoph Scheidereiter**  
Council: PSAWP

**Mark Sleep**  
SAPSF Exco, CFR Representative

**Marek Stawicki**  
Council: KZNPA

**Leon Stander**  
SAPSF President

**Chris Venter**  
Council: LPSA

**Phil Verity**  
Council: PSAWP

**George Vergos**  
Council: GPSA

### Special Thanks

A special thank you to Dr Leon Stander for his significant contributions and dedication in leading the majority of the revisions that resulted in the finalization of Revision Nine of this rule book.

# SAPSF Executive Sanction: Rule Book Approval

**This revised Rule Book (9<sup>th</sup> Edition) was amended and approved by the Council members on the 28<sup>th</sup> February 2026 and co-signed by the members of the Executive of the South African Pin Shooting Association, as well as by the provincial chairmen of the four active provinces.**

Thus, signed and accepted this \_\_\_ day of \_\_\_\_\_ on behalf of the SOUTH AFRICAN PIN SHOOTING FEDERATION:

**JORGE GONCALVES**

SAPSF President

\_\_\_\_\_

**DAVID SUNJICH**

SAPSF Vice President, Chairman GPSA

\_\_\_\_\_

**KEVIN ADDISON**

Council Member, Chairman PSAWP

**Gary Cullingworth**

Council Member, Vice Chairman PSAWP

**ALWIN FLEISCHMANN**

Council Member LPSA

**TINNIE NIEUWOUDT**

Council Member LPSA

**STEFANO GHIGINI**

Council Member GPSA

**STEPHEN MARAIS**

Council Member GPSA, SAPSF Executive, CRO

**TINUS BOTHA**

Chairman LPSA

**MAREK STAWICKI**

Chairman KNZPSA

Personal Notes.....



**LIMPOPO PIN SHOOTING ASSOCIATION**



**PIN SHOOTING ASSOCIATION WESTERN PROVINCE**



**KWA ZULU-NATAL PIN SHOOTING ASSOCIATION**



**FREE STATE PIN SHOOTING ASSOCIATION**



**GAUTENG PIN SHOOTING ASSOCIATION**